

**HITCH ADAPTOR ASSEMBLY:**  
W/ OPTIONAL ACCESSORY SHOWN

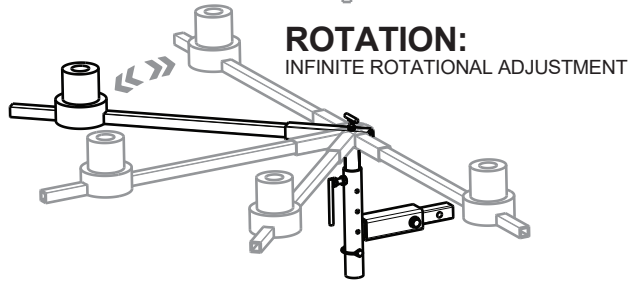

**ROTATION:**  
INFINITE ROTATIONAL ADJUSTMENT

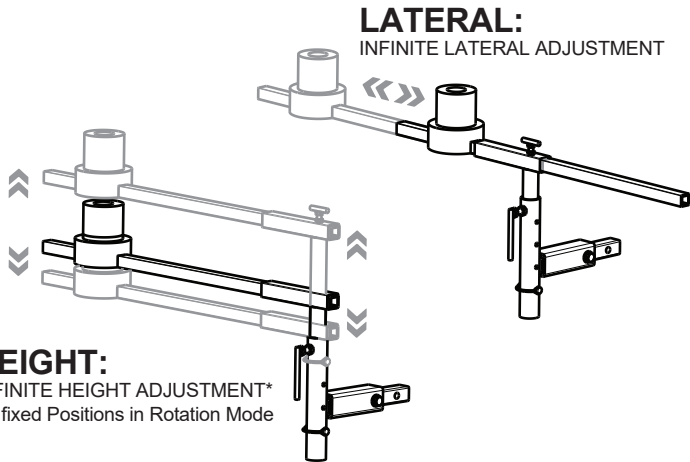
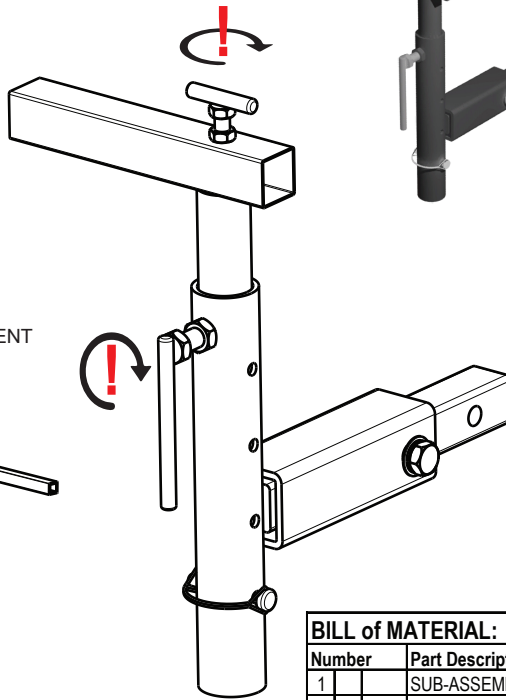

**LATERAL:**  
INFINITE LATERAL ADJUSTMENT

**HEIGHT:**  
INFINITE HEIGHT ADJUSTMENT\*  
\* 5 fixed Positions in Rotation Mode

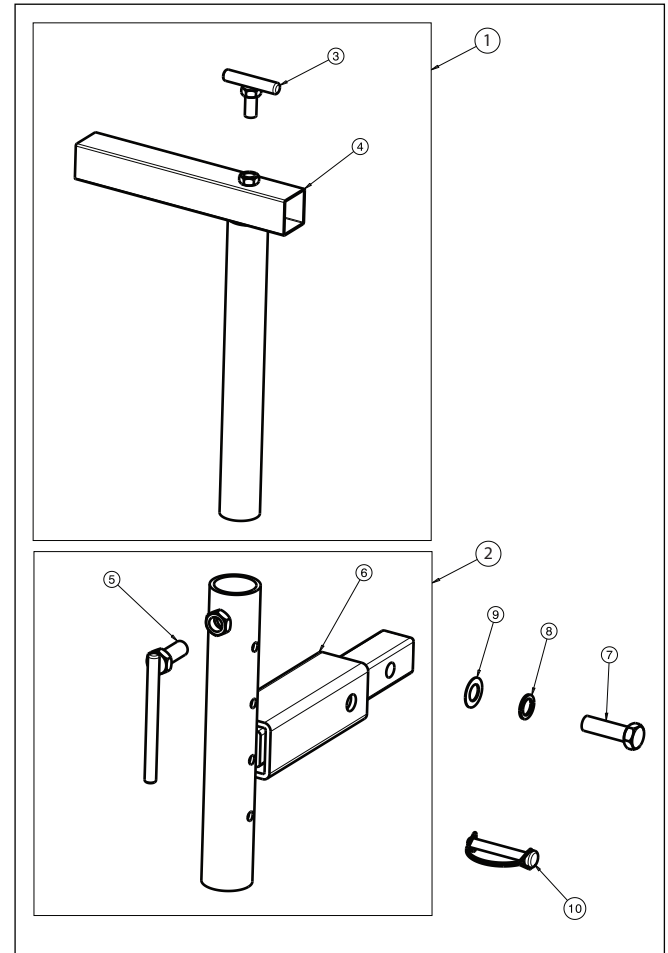

**HITCH ADAPTOR ASSEMBLY**

BILL of MATERIAL: HITCH ADAPTOR ASSEMBLY			
Number	Part Description	Definition	Quantity
1	SUB-ASSEMBLY UPPER - PART 1	ADJUSTABLE - Height and Rotational	1
2	SUB-ASSEMBLY LOWER - PART 2	FIX-MOUNT to HITCH RECEIVER (1-1/4" or 2")	1
3	! T-Handle	to SECURE Lateral Adjustability of Mounted Accessory	1
4	ACCESSORY ATTACH - Upper	to Mount and Rotate Accessory	1
5	! L-Handle	to SECURE Vertical Adjustability of Mounted Accessory	1
6	HITCH RECEIVER ATTACH - Lower	to Fix-Mount to either 1-1/4" or 2" Hitch Receiver	1
7	! BOLT	Hex Bolt 1/2"-13 x 2"	1
8	SPLIT LOCK WASHER	Split Lock Washer 1/2"	1
9	FLAT WASHER	Flat Washer 1/2"	1
10	WIRE LOCK PIN	Round Wire Lock Pin 5/16" x 2-1/2"	1

**!** ALWAYS TIGHTEN FULLY TO LOCK AND SECURE DURING TRAVEL  
DO NOT LEAVE ANY ACCESSORIES MOUNTED DURING TRAVEL