

AL500 Universal Power Chair Lift
Capacity: 350 lbs

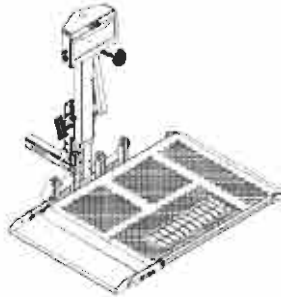

AL100 Universal Scooter Lift
Capacity: 350 lbs

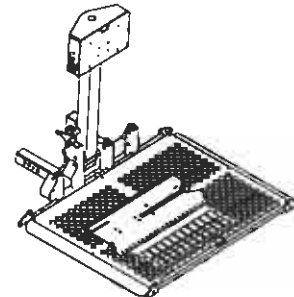

AL550 Automatic Power Chair Lift
Capacity: 350 lbs

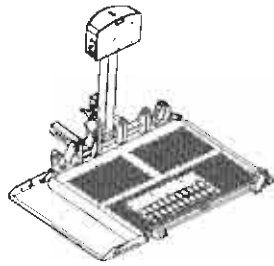

**AL300 Universal Power Chair /
Scooter Lift**
Capacity: 350 lbs

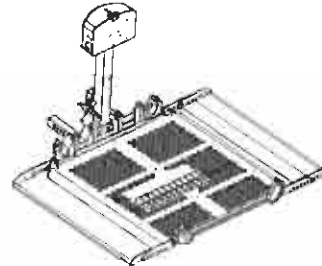

**AL301XL Extra Wide Power Chair /
Scooter Lift**
Capacity: 350 lbs

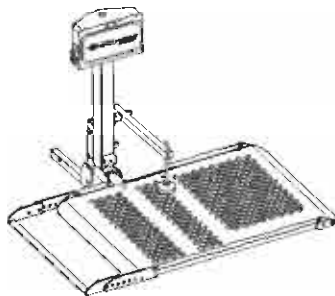

AL010 Micro Scooter Lift
Capacity: 135 lbs

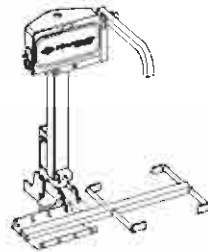

**AL030 Power Tote for
Manual Wheelchairs**
Capacity: 100 lbs

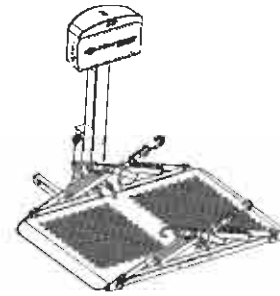

**AL050 Micro power
Chair Lift**
Capacity: 135 lbs



Read manual thoroughly before attempting to install or operate lift.

This manual has been provided to assist you with lift installation and operation. For further assistance please contact your authorized Harmar Mobility dealer or Harmar's Technical Services department.

Tel: 800.833.0478

Fax: 866.234.0478

Email: tech@harmar.com

Dealer:

Serial Number:

Unpacking the Lift

Your Universal Outside Lift was factory pre-assembled to require little assembly before installation. Box contents should include:

AL500

- Package Check List**
 Main lift body (# 1)
 Hitch Post (# 2)
 Hitch Adapter (# 3)
 Anchor Plate
 Hardware pack

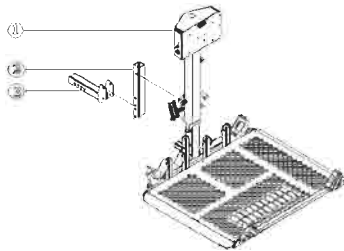

AL100

- Package Check List**
 Main lift body (# 1)
 Hitch Post (# 2)
 Hitch Adapter (# 3)
 Spreader Bar (# 4)
 Hardware pack

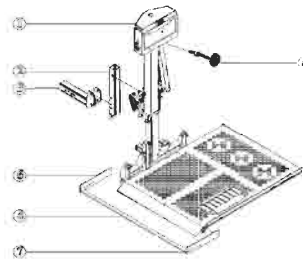

Hardware Package

- Contents Include:**
 Vehicle Wiring Harness
 Required Fasteners
 Keys
 Black tie wraps
 Instruction Manual

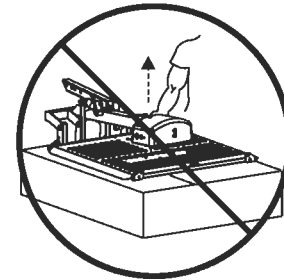

**DO NOT
 LIFT
 FROM
 MOTOR
 COVER**

AL550

- Package Check List**
 Main lift body (#1)
 Hitch Post (#2)
 Hitch Adapter (#3)
 Hardware pack

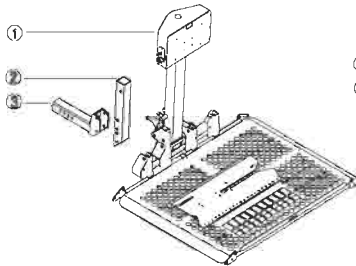

AL300

- Package Check List**
 Main lift body (# 1)
 Hitch Post (# 2)
 Hitch Adapter (# 3)
 Spreader Bar (# 4)
 Hardware pack

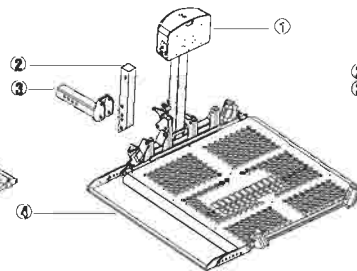

AL301XL

- Package Check List**
 Main lift body (# 1)
 Hitch Post (# 2)
 Hitch Adapter (# 3)
 Rear Wheel Cradle (# 4)
 Front Wheel Cradle (# 5)
 Hardware pack

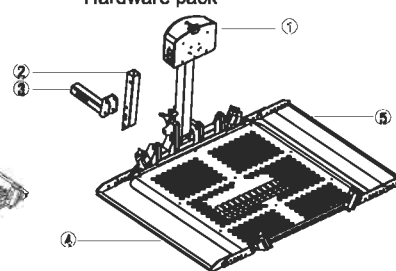

NOTE: The Platform will not be allowed to unfold until the platform has been lowered at least 1 inch.

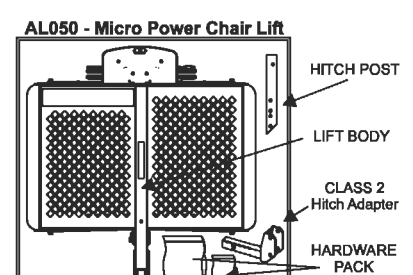
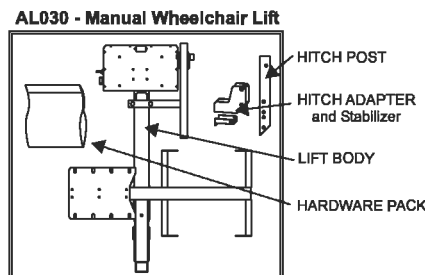
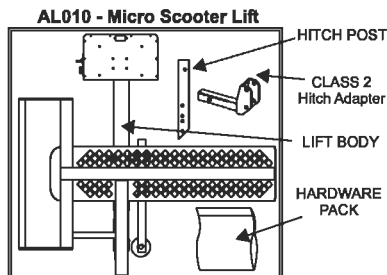
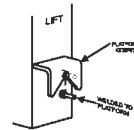

Be sure and check the contents of the box against the package check list to be sure that all parts are included with the lift that are required for proper installation. If any parts are missing or if any damage is noted, immediately contact the distributor from which you purchased your lift. **DO NOT attempt to install or use the lift with any missing or damaged parts.**

Vehicle Wiring Harness Installation Instructions

- 1 Unwind the harness and lay it flat. One end of the harness has a black plug. This end of the harness goes to the back of the vehicle.

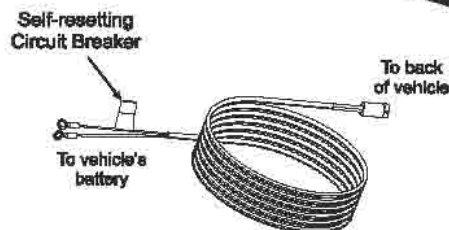

- 2 **BEGIN ROUTING THE VEHICLE HARNESS AT THE BATTERY**
Attach the black wire to the negative terminal on the battery. Do not attach the red wire yet.

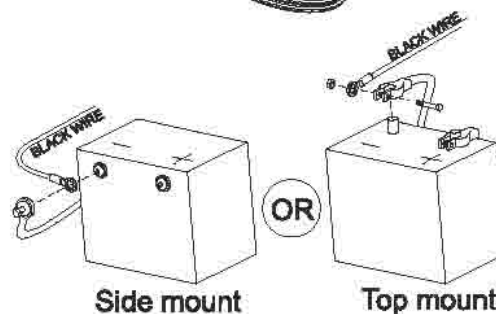

- 3 Run the wiring harness under, or when possible through the vehicle, back to the trailer hitch. Always locate the wiring harness where it can not be snagged by road debris and away from the vehicle's gas tank. If the harness is too long for the vehicle, coil the excess wire and secure it to the vehicle frame with cable ties. Do not cut or shorten the harness. Secure the plug about even with the end of the hitch receiver tube.

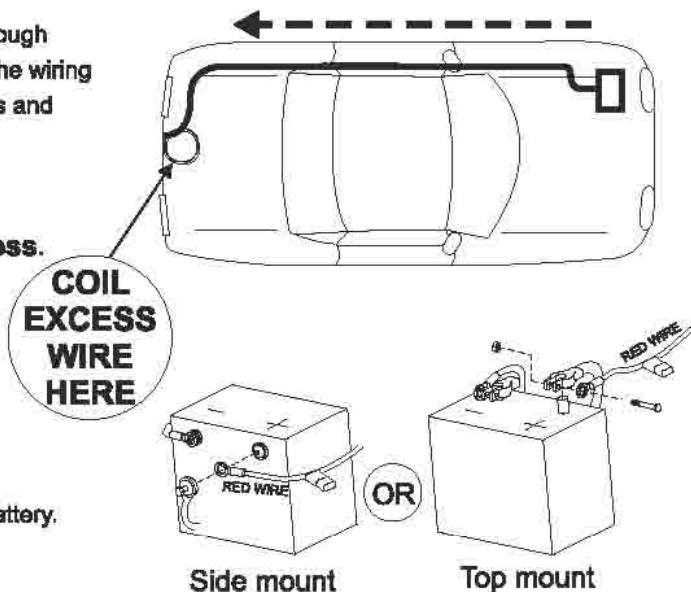

- 4 Attach the red wire to the positive terminal on the battery.

- 5 Wire in a Standard 4-contact female flat trailer connector to the vehicles' taillights. This will provide power for the motor cover light.



Important Reminder: Never attempt to attach the wire harness to a secondary power source. The harness requires direct connection to the battery.

Caution: Route the harness away from the exhaust system, brake lines, fuel lines, gas tank, pinch points, and sharp edges. Locate the wiring harness where it can not be snagged by road debris.

Vehicle Hitch

To install an Outside Lift on a vehicle, the vehicle must be capable of accepting a Class 2 or Class 3 hitch. If you are unsure about the vehicle and hitch compatibility, contact a local hitch installer or the web sites below. The vehicle should also be wired with standard 4 post trailer wiring.



Listed below are three websites of hitch companies that can be used as a reference
www.hitch-web.com, www.reeseprod.com, or www.draw-lite.com

Be sure to recommend a hitch installer that is reputable, insured, and capable, as their work has a direct reflection on the customers perception of a properly installed mobility lift.

Important Note: Not every vehicle is capable of having a hitch installed

Remember: Calculate the weights of the lift, mobility device, and where applicable the swing away option, being certain that the total weight does not exceed the recommended tongue weight of the hitch. Different types of hitches are capable of bearing different amount of tongue weight.

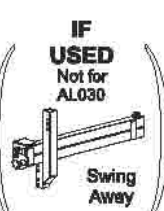
The lift manufacturer suggests the installer observe the vehicles and **Gross Vehicle Weight Ratings Restrictions.**

PRODUCT:	HITCH CLASS:	WEIGHT:							
AL100	2 or 3	98 lbs	}	+		+		=	<div style="border: 1px solid black; padding: 5px; display: inline-block;"> Must NOT Exceed Hitch lbs Manufacturer's Max Tongue Weight </div>
AL500	2 or 3	95 lbs							
AL550	2 or 3	112 lbs							
AL300	2 or 3	127 lbs							
AL301XL	2 or 3	135 lbs							
AL010	2 or 3	73 lbs							
AL030	1, 2 or 3	60 lbs							
AL050	2 or 3	70 lbs							

Important Note: Some states have very strict license plate obstruction laws, so be sure to familiarize yourself with the local and state laws.

Important Note: Assure the receiver tube of the hitch is parallel to the ground. This is not a recommendation, but rather a requirement.

If the hitch is not installed properly, it will affect the functioning of the lift.

Some vehicles will require that the rear suspension be supplemented. The manufacturer recommends the installer contact a suspension specialist for additional technical support.

A vehicle with a Class 3 (Class 2 requires optional accessories) hitch and standard 4 post trailer wiring is ready for installation of the lift.

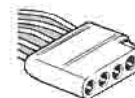

Hitch Adapters

AL123
Standard Class 3

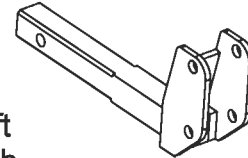
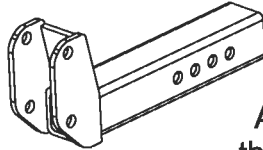

AL126
Standard Class 2

A Hitch Adapter is the part of the lift that plugs into a vehicle's trailer hitch. Several hitch adapters are available to fit the needs of different vehicles. When selecting a Hitch Adapter you should determine the **hitch class** and measure the **bumper distance**.

AL125
Class 3 Extra long

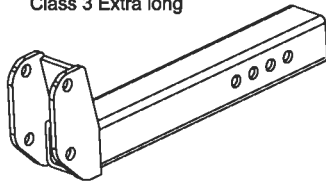

AL127
Class 2 Extra long

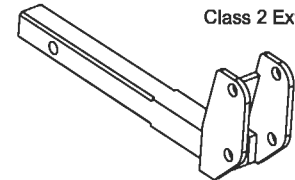

Bumper distance is the length from the trailer hitch's bolt hole to the rear most point on the vehicle.

H124
Class 3 Short

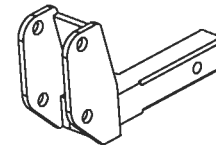
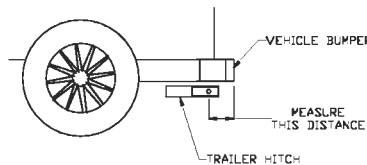
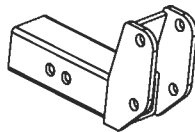

H128
Class 2 Short

Hitch class is usually printed on the trailer hitch, however it can also be determined by measuring the inside of the receiver on the trailer hitch.

Class 2 hitches measure 1-1/4" x 1-1/4"

Class 3 hitches measure 2" x 2"

AL1232
2in Drop Class 3

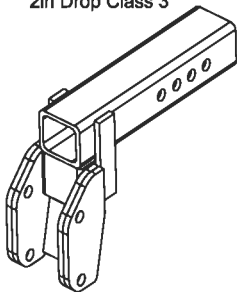

Once you have determined the hitch class and bumper distance, refer to the diagram below to select the proper hitch adapter. As always, Harmar Mobility's trained personnel will be glad to assist you in selecting the proper hitch adapter.

AL1235
5in Drop Class 3

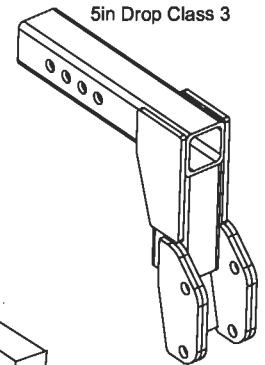

AL1236
6in Drop Class 3

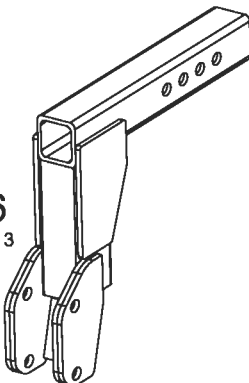

Hitch Class	Bumper Distance	Bumper Distance	Bumper Distance
Class II	0"-7.5"	7.5"-10"	10"-13.5"
	AL126	AL127	
Class III	AL123	AL125	AL125

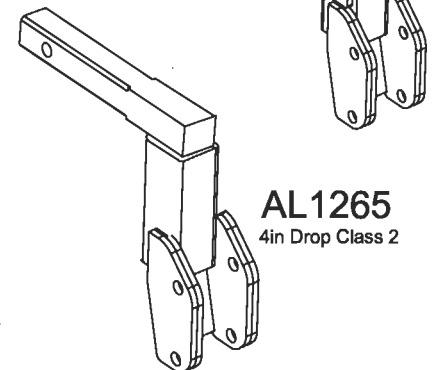

AL1265
4in Drop Class 2

Shorter adapters available for shallow hitches.
Drop adapters available for higher than normal vehicles.

Installation

In order to determine how to assemble the Hitch Post and Hitch Adapter, the distance from the bottom of the hitch to the ground must be measured. Determine which set of holes to use to bolt together the Hitch Post and Hitch Adapter. Use the 1/2" x 3-1/2" bolts and nuts provided and tighten.

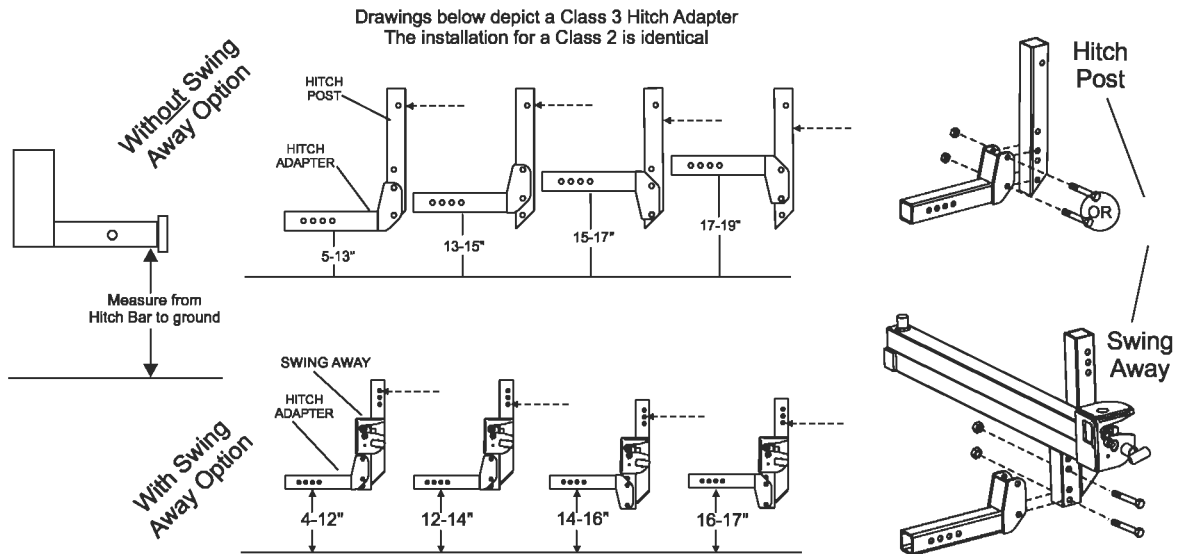

Once you have determined the proper adjustment for the Hitch Post or Swing Away and have attached it to the Hitch Adapter, insert the adapter into the hitch receiver and attach it using the 1/2" x 3-1/2" bolt, Pinch Bolt Tube and lock nut.

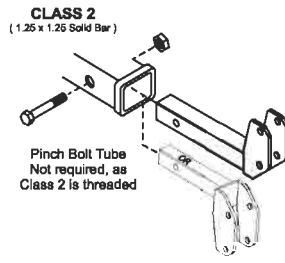
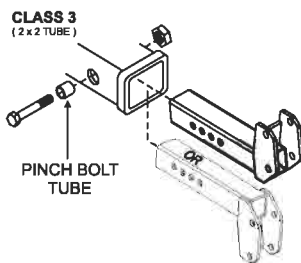

NOTE: Pinch Bolt Tube is added to the Class 3 receiver bolt to prevent the lift from moving side to side

Attach Lift to Hitch Post or Swing Away

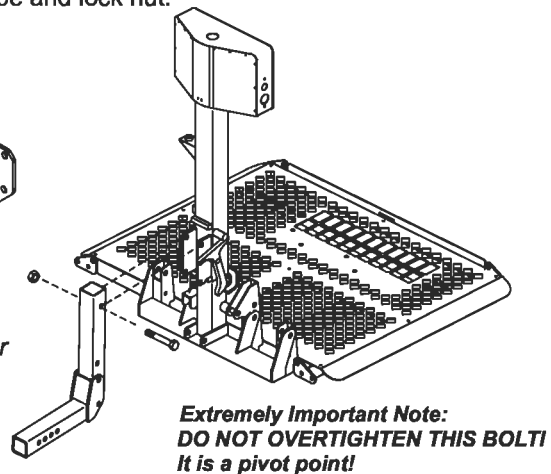

Valuable Installation Hint! (Using Caution), Once the lift is placed behind the vehicle, plug the power cord into the harness that you have installed on the vehicle. Turn the key on and use the toggle DOWN switch to raise the motor box. Continue to power the lift until the mounting holes in the lift are even with the top hole in the Hitch Post. Attach the lift to the post using the supplied 1/2" bolt with lock nut and washers. Using this method will allow you to attach the lift without physically having to lift the unit and hold it while the bolt is inserted.

Route the lift power cord down the lift away from its moving parts and potential pinch points. The cord should follow along the post and be secured with zip ties provided to allow the lift to operate without disconnecting the power cord.

Installation

FOR AL030 ONLY
(CLASS 1)

Bumper Mount
(Be sure to comply with
vehicle's bumper rating)

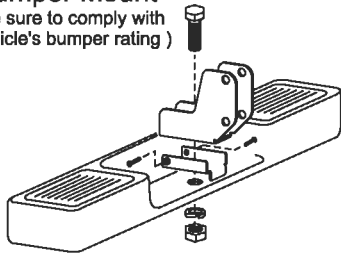

Flat Bar Style
(Be sure to comply with
vehicle's bumper rating)

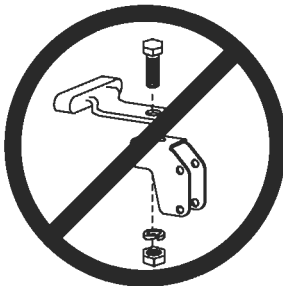
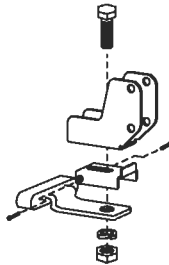

Do not attempt to
mount up from under

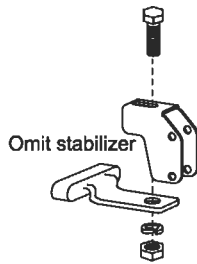

CLASS 1 Hitch Adapter
can NOT be used when
installing a Swing Away

For AL030 ONLY

Class 1 Hitch
and stabilizer

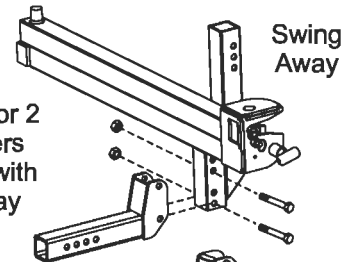
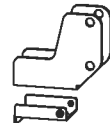

Only Class 3 or 2
Hitch Adapters
can be used with
a Swing Away

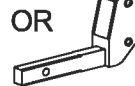

Drawings below depict a Class 1 Hitch Adapter
The installation for a Class 2 or 3 Hitch
adapter can be used and is identical

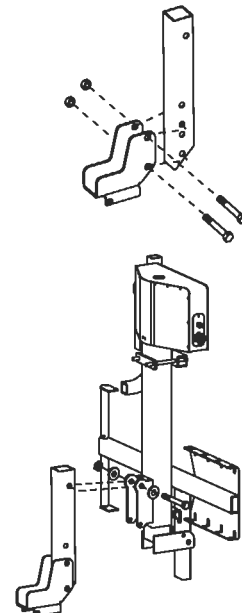
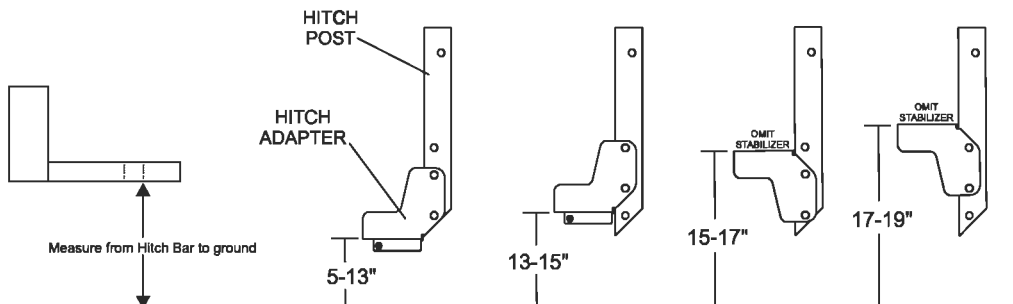

Chair Preparation

AL500, AL300, AL301XL, and AL050

There are 2 options on how to attach the strap hooks to the chair that are included with the lift. The options consist of using either the Anchor Plate or the Anchor U-Bolts.

Anchor Plate: The Anchor Plate is a bar that is 20" long and 2-1/2" wide with 2 holes in each end. This plate will work with any chair that has a center seat post that attaches to the bottom of the seat. Attach the Anchor Plate by the following these steps:

1. Remove the seat from the chair and turn it over.
2. Loosen the screws that attach the plate to the bottom of the seat. Allow enough room to slide the Anchor Plate between the seat and the seat plate.
3. Attach the Anchor Plate in the center of the seat plate with the holes on each end extending evenly on each side of the seat.
4. Retighten the screws that hold the seat plate to the bottom of the seat.
5. Replace the seat on the chair.

The Anchor Plate should extend about 1-1/2" out from the side of the seat cushion. This will allow the user to attach the strap hooks to the Anchor Plate to secure the chair to the lift.

Note: Anchor Plates are available in 24" and 27" sizes for special applications.

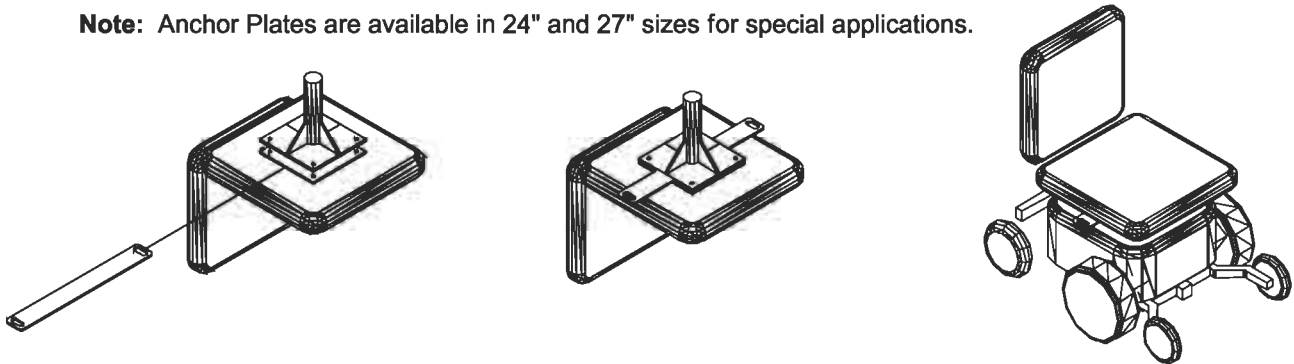

Anchor U-Bolts: The U-Bolts are included to be used with Power Chairs that do not have a center seat post. On this type of chair, the seat is normally attached to a tubular frame. Attach the U-Bolts, one on each side, to the frame as shown above. Make sure that the loop extends to the outside of the chair to allow the strap hooks to be attached by the end user.

Each type of chair will differ slightly and the placement of the U-bolts will differ between different models and manufacturers. Place the Anchor U-Bolts towards the center of the seat if possible. Because of the different types of seats, you may be forced to attach the Anchor U-Bolts more towards the front or rear of the seat, but we recommend attachment as close as possible to the center of the seat.

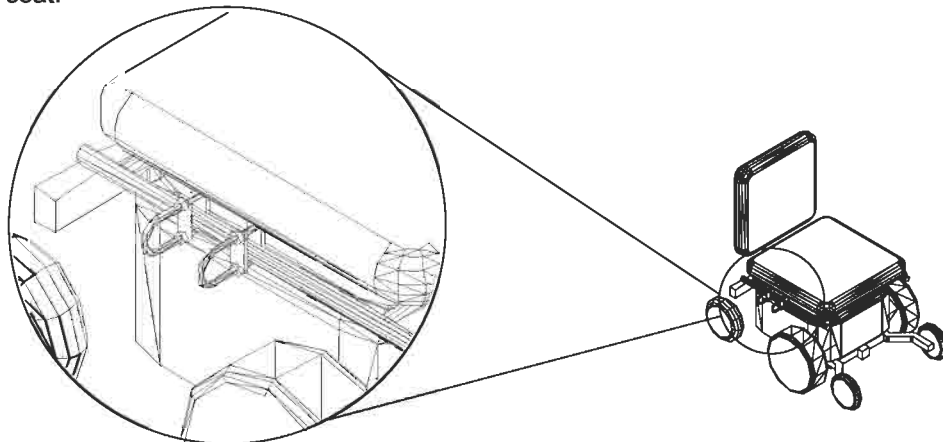

AL550 only

CHOOSING A LOCATION and MOUNTING THE DOCKING DEVICE PLATE

WARNING: Do not attempt to use this automatic lock down device on any folding, or take apart chairs unless recommended by Harmar.

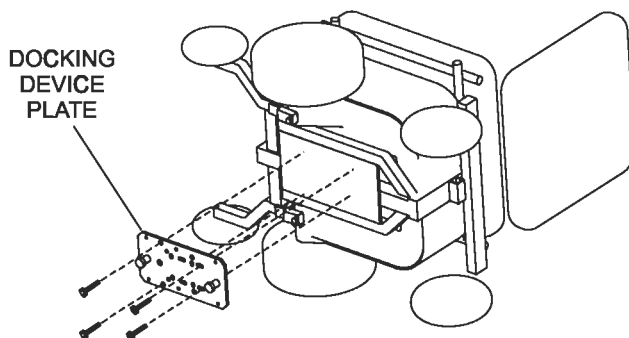
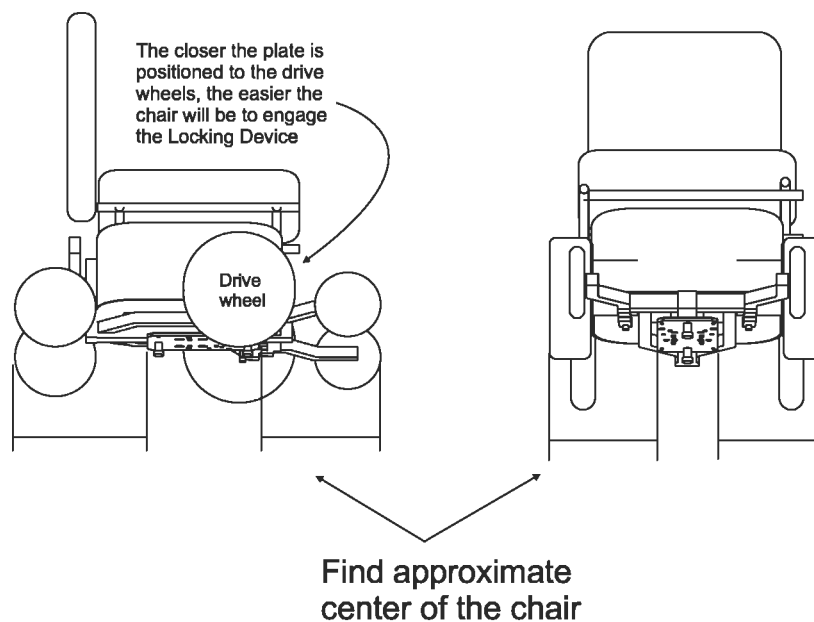

Use existing holes where ever possible.

If too little or no holes exist, holes need to be drilled. Remove power chair's batteries, and use plate as a template. Drill as required.

Attach to chair using supplied hardware.

4---1/4-20 x 1.00" HHCS

4---1/4-20 Nylock Nut

ATTACHED TO PLATE

Lift Preparation

AL550 only

SETTING DOCKING DEVICE HEIGHT

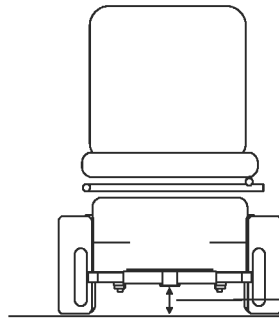

Measure distance of mounting surface to ground

PRIOR TO MOUNTING DOCKING PLATE TO CHAIR
Ground clearance MUST be greater than or equal to 1.75"

Determine number of spacers required for your ground clearance

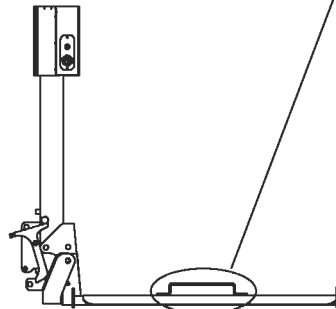

Remove Locking Device and insert appropriate number of spacers. Re-attach to platform. (change to longer screws if necessary)

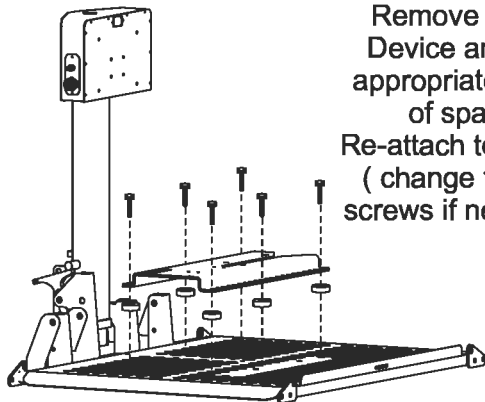

If ground clearance =	Then use;	Hardware Used: (from hardware pack)
1.75" - 2"	No Spacers	 Mounted on lift from factory 1" x6
2.25"	.25" spacers	
2.5"	.5" spacers	
2.75"	.75" spacers	 1.75" x6
3"	1" spacers	
3.25"	1" + .25" spacers	
3.5"	1" + .5" spacers	 2.5" x6
3.75"	1" + .5" + .25" spacers	
4"	1" + 1" spacers	
4.25"	1" + 1" + .25" spacers	 3.25" x6
4.5"	1" + 1" + .5" spacers	
4.75"	1" + 1" + .5" + .25" spacers	

Drive Chair onto Lift

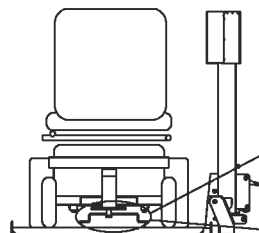
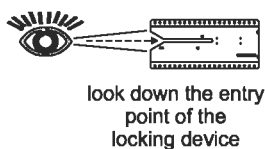

Verify the head of the shoulder bolt is below the underside of the locking device.
UP TO 1/4" OF SPACE IS ACCEPTABLE

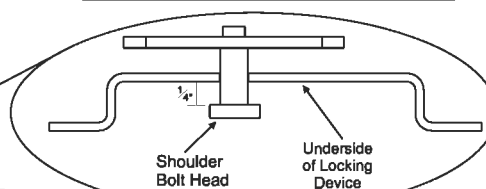

Perform lock down test on next page to assure installation of Docking Device Plate and Locking Device are correct.

AL100 and AL010

SETTING HOLD DOWN FOOT HEIGHT

With platform on the ground, drive scooter onto platform, from left (driver's side) to right, until the rear wheels are located in the rear wheel spreader bar assembly. Stop when the rear tires contact the ramp on the platform.

On the AL010, rotate the Hold Down Arm upright. Raise the platform on either lift until the motor's clutch is heard (top of travel). Loosen both nuts on hold down arm, and thread the Hold Down Foot down to the scooter's deck. Lower Platform about 1-2 inches. Thread Hold Down Foot down once again to scooter's deck. Raise Platform. Verify Hold Down Foot places adequate pressure on scooter.

DO NOT adjust the leg so far down that the top of the threaded rod does not protrude through the top of the pivot tube. Once the foot is adjusted to the proper position, tighten the jam nut to lock it in place.

Once the lift is properly adjusted, lower the platform to the ground and raise it back to the transporting position. Repeat this several times to make sure all parts are operating properly and that the scooter is properly secured. Next, remove the scooter from the lift and using the toggle switch, cycle the lift completely up and down to make sure that all parts are in working order and the lift folds up when it is empty.

Caution: On some scooters, it may be necessary to temporarily move the steering tiller forward to clear the hold down arm as it lowers into the lock down position.

Caution: Some scooters have pneumatic (air inflated) tires. If your scooter has this type tire, be sure the tires are properly inflated. Improper inflation of the tires will change the deck height of the scooter and therefore change the amount of clamping force the hold down arm places on the scooter. The scooter can fall off of the lift if not properly secured.

Caution: Be sure to instruct the end user not to enter steep driveways straight on. Enter and leave at an angle to the street so that your lift platform does not drag on the ground.

NOTE: Drive the scooter off in *REVERSE* When the scooter is clear of the platform, raise the platform by pushing up on the *UP/DOWN* switch.

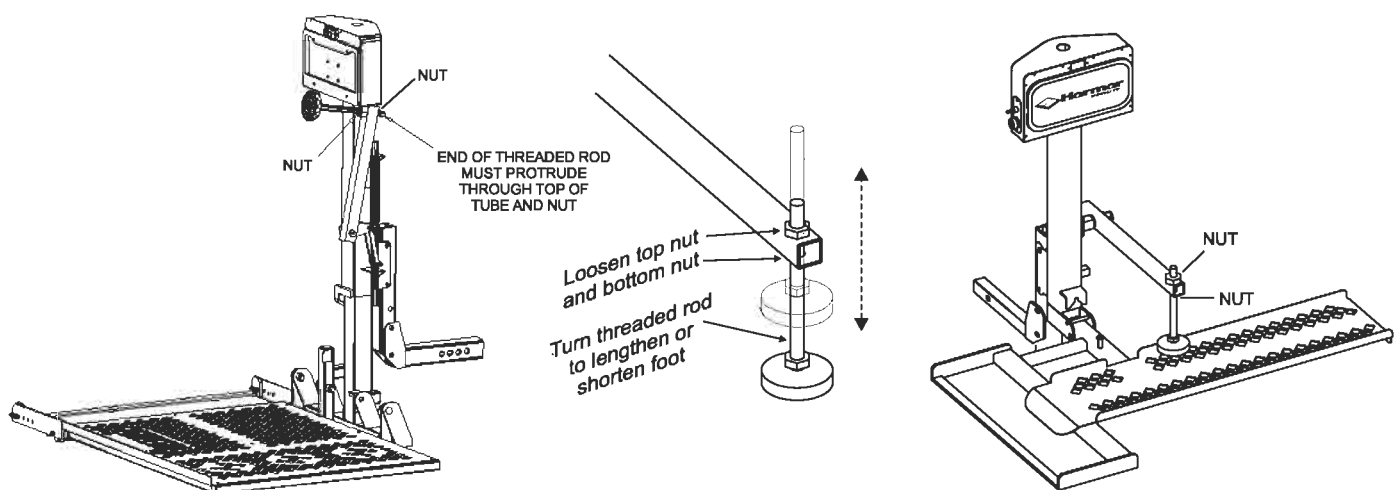

Lift Preparation

AL010 and AL030 PIVOT POINT ADJUSTMENTS

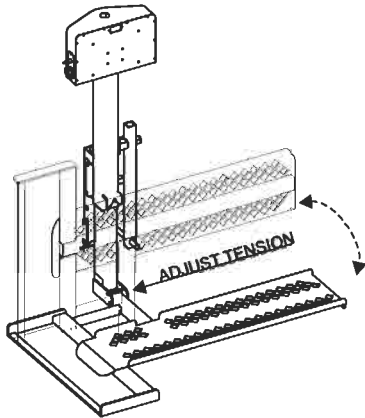

The hinge points are equipped with tensioning washers. The amount of force required to move these parts is determined by the tension of these washers. To adjust, simply loosen or tighten the bolt and nut located by w/ arrows. The tension is set at the factory and should need no adjustment. This is noted for reference only.

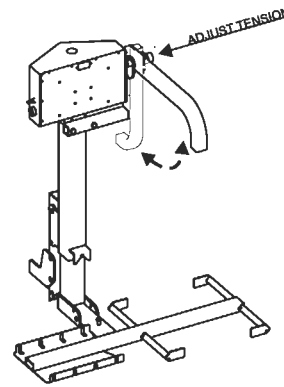
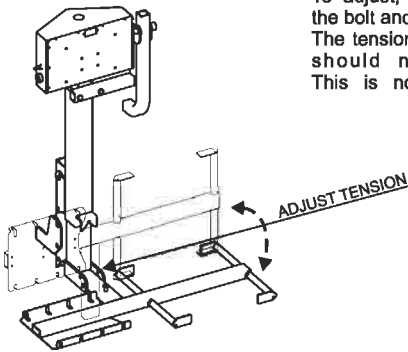
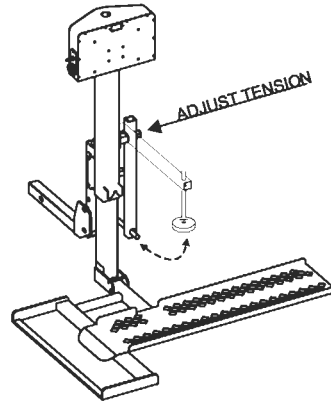

AL010 and AL030 HOLD DOWN ARM ADJUSTMENT

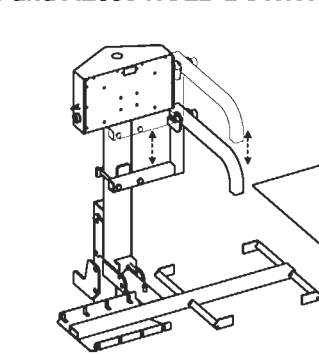

Loosen nuts here

- Slide arm up or down tube
- Tighten after adjustment

LIFT SHOULD HOLD WHEELCHAIR FIRMLY WITH THE PLATFORM FULLY RAISED (RAISED UNTIL MOTOR RATCHETING IS HEARD)

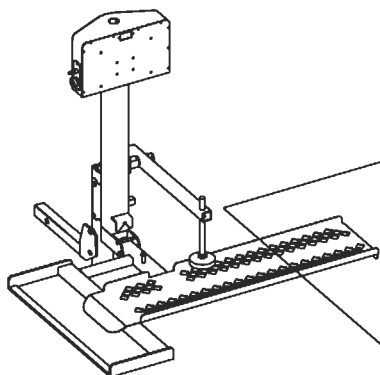

Loosen top nut and bottom nut
Turn threaded rod to lengthen or shorten foot

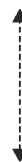

LIFT SHOULD HOLD SCOOTER FIRMLY WITH THE PLATFORM FULLY RAISED (RAISED UNTIL MOTOR RATCHETING IS HEARD)

General Operating Instructions:

Turn the key switch to the ON position. With the toggle switch, raise and lower the platform as needed. Pushing the switch downward will cause the platform to lower. The platform will first unfold to the horizontal position, then continue lowering to the ground. Release the UP/DOWN toggle switch just as the platform reaches the ground. **Do not attempt to raise the rear of the vehicle with the lift or damage could be done to your lift or vehicle.**

Drive the chair/scooter onto the platform as close to the center of the platform as possible. Follow the instructions for securing the chair/scooter onto the lift. Raise the platform to the transporting position. Now lower the platform to the ground. Repeat this action to make sure all parts are operating properly and the chair is properly secured.

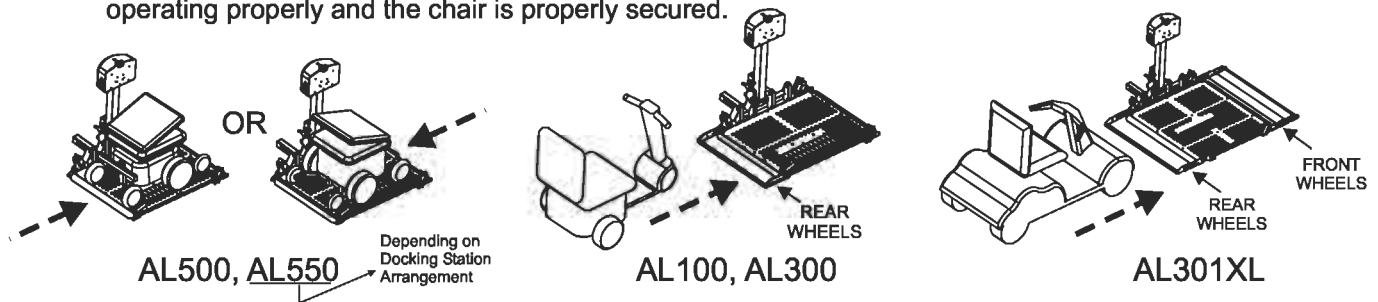

Next, remove the chair/scooter from the lift and using the toggle switch, cycle the lift completely up to make sure that all parts are in working order and that the lift folds up when it is empty.

Make absolutely sure the chair/scooter is properly secured by the locking mechanisms. Be sure everything is in proper working order before transporting any chair/scooter.

CAUTION: Keep hands and feet out from under the platform as it raises and lowers.

CAUTION: Before driving off with the chair/scooter on the lift, make sure that the chair/scooter is firmly held down on the platform.

CAUTION: When driving with the chair on the lift, instruct the end user to slow down for pot holes, speed bumps, railroad tracks, etc. The lift could be damaged by this type or similar abuse. Lifts are subjected to excessive loads imposed by rough driving.

CAUTION: Be sure to instruct the end user, do not enter steep driveways straight on. Enter and leave at an angle to the street so that the lift platform does not drag on the ground.

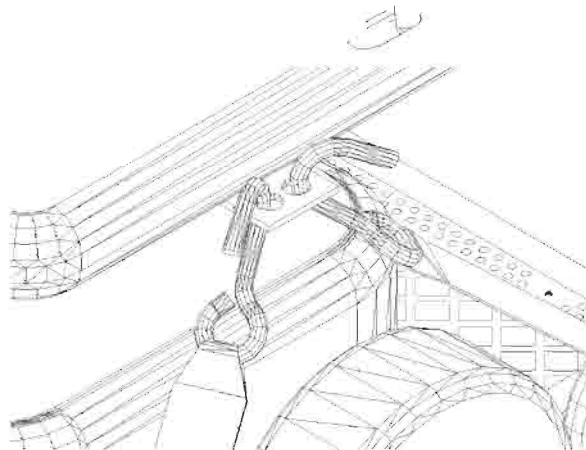
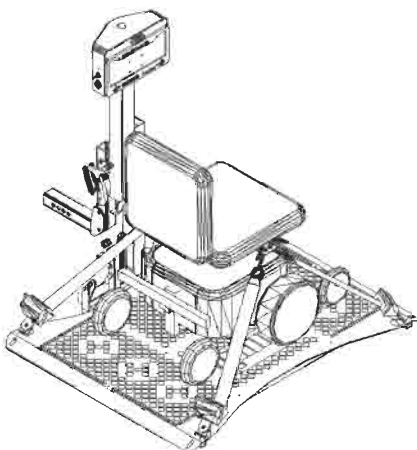

Operation

To unload the power chair, simply turn ON the power switch and push the UP/DOWN toggle switch to the down position. Hold the switch down until the platform just touches and is level to the ground. Press the red release button on the Anchor Strap Base to release the tension and unhook the strap from the chair. Continuing to press the button, allow the strap to retract until the hook reaches the housing. Repeat this step on each corner until all four straps are released. Drive your power chair off the lift platform. When the power chair is clear of the platform, raise the platform by pushing up on the UP/DOWN switch.

To bring the lift in the empty, stowed position, hold the UP switch. The platform will start up in the horizontal position. During its travel upward, the platform will fold up into the stowed or vertical position. Hold the switch until the platform travel stops automatically.

Courtesy Note: You may wish to advise the end user to remove the key from the power switch to avoid any tampering with the lift.

Special Note: The lift features a manual override. If the vehicle or lift loses power, simply remove the CAUTION STICKER from the top of the motor box and using a 3/8" socket, turn the wrench clockwise to raise the lift and counter clockwise to lower the lift. *(If the lift does not operate properly, immediately take it to the local dealer. DO NOT attempt to modify the lift in any way!)*

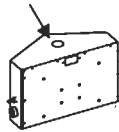

Do not attempt to move the vehicle without the lift in the stowed or travel position. Any attempt to move the vehicle without the lift fully up may cause damage to the lift, power chair, scooter or vehicle.

The **AL100** is shipped with the Spreader Bar Assembly already attached to the back of the platform on the lift. You must rotate it down until the hole in the side bracket lines up with the open hole on the attachment point on the platform. The Spreader Bar should be flat on the ground at this point. Tighten the bolts where the Spreader Bar Assembly attaches to the platform.

Load the scooter on the center of the platform. Adjust the spreader bar according to the size of the scooter that is being transported on the lift. Forward for smaller scooters and back for larger scooters. Make sure that all fasteners on the Spreader Bar Assembly are tightened before attempting to use the lift.

With the toggle switch, raise the platform with the scooter on it. You will notice that as the lift reached the top, the hold down arm with the foot will lower to the deck of the scooter. The foot should put pressure down on the deck of the scooter to secure it in place while traveling. If the foot does not reach the scooter, unthread the adjustable leg until the foot rests securely on the deck of the scooter.

Thread the Adjustable Hold Down Foot onto the hold down arm. To begin, thread the rod completely into the arm. Lower the platform to the ground and place the scooter to be used on the lift and using the toggle switch, raise the platform and scooter up until it reaches the traveling position (all the way up). The lifting motor has a clutch mechanism that will stop the lift when it reaches the top. You will hear a clicking sound when the lift is at the top. Release the switch at this time.

AL550

LOADING THE POWER CHAIR

1

Insert and turn key. Press down on switch to lower platform.

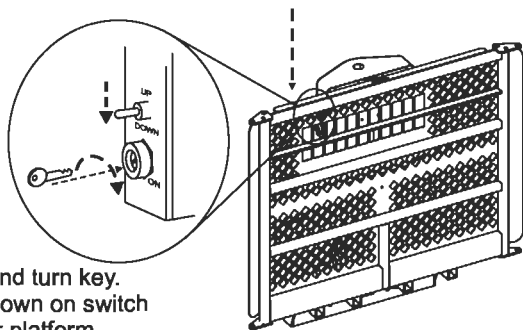

2

Continue to lower as platform automatically unfolds. Stop when platform reaches ground.

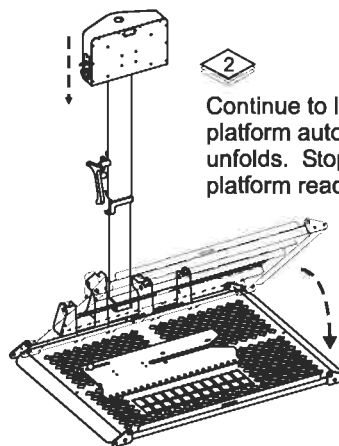

3

Slowly drive chair onto platform as shown.

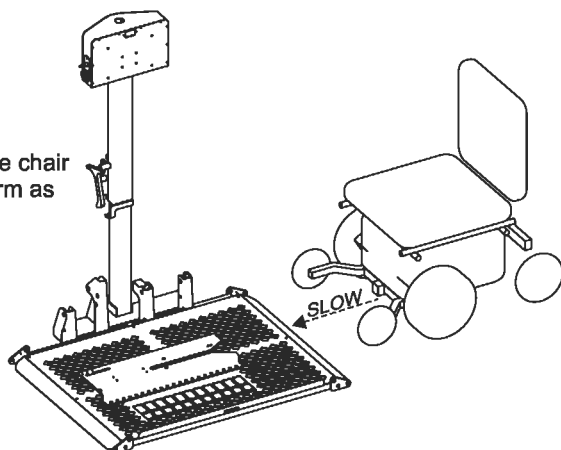

4

TEST LOCKING DEVICE

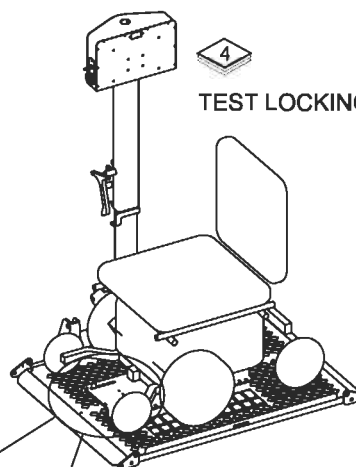

THREE WAYS TO VERIFY YOUR CHAIR IS SUCCESSFULLY LOCKED DOWN

1) AUDIBLE "CLICK or POP" SOUND

As the chair enters the locking device, it should be driven forward until an audible pop or clicking sound is heard. This sound is the locking device setting itself around the chair's docking device pin.

2) VISUAL INDICATOR

The yellow indicator will extend and stay extended when the chair is successfully locked in place.

3) REVERSE TEST

Attempt to back the chair off the platform. The chair will NOT move in any direction when successfully locked.

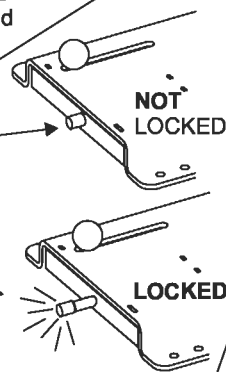

5

AFTER ALL THREE TESTS ARE PERFORMED Raise platform until motor's clicking noise is heard

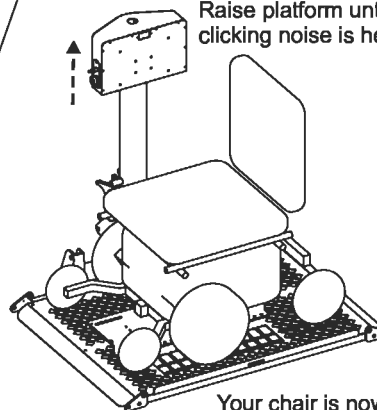

Your chair is now ready for transport. Remove key if desired.

Operation

AL550

UNLOADING THE POWER CHAIR

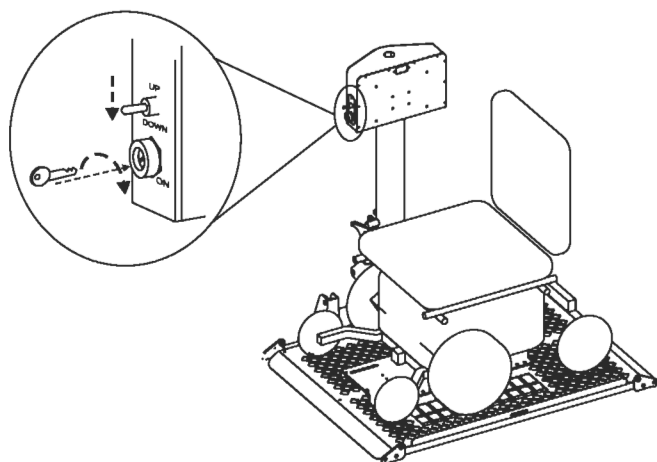

1

Insert and turn key.
Press down on switch
to lower platform.

To avoid bending over,
you may wish to release
chair from Locking Device
prior to lowering platform.
Be sure the drive wheels
are engaged, and the chair's
power is OFF.

2

TO RELEASE CHAIR
Slide knob this direction

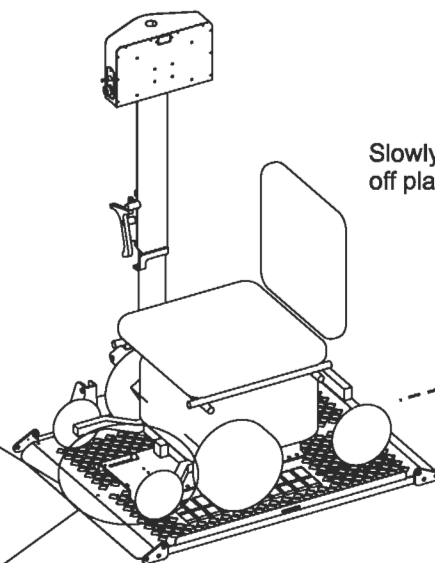
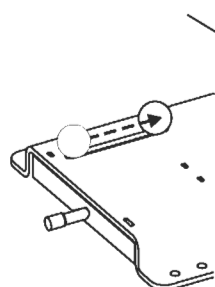

Slowly back chair
off platform

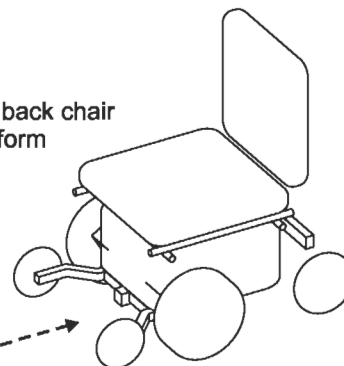

NOTE: During transport, vibration
may cause the chair to tighten itself in
the locking device, making the release
knob difficult to slide. To overcome this,
simply drive the chair forward a bit.
This will take pressure off the knob,
allowing an easier release.

3

Raise the platform
by pressing up on
the switch until
motor's clicking
noise is heard.
Platform will fold
automatically.
Remove the key
if desired.

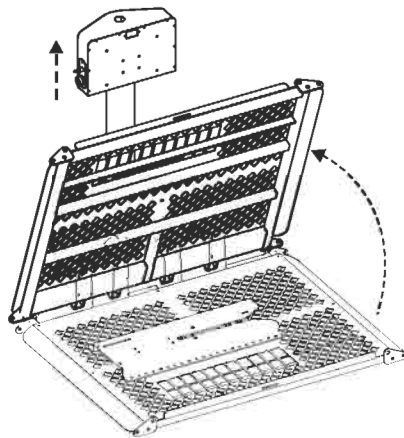

Once the chair has left the locking device,
it automatically resets itself to accept the
next time the chair needs to be transported.
No adjustment of the release knob is required.

AL010

LOADING THE SCOOTER

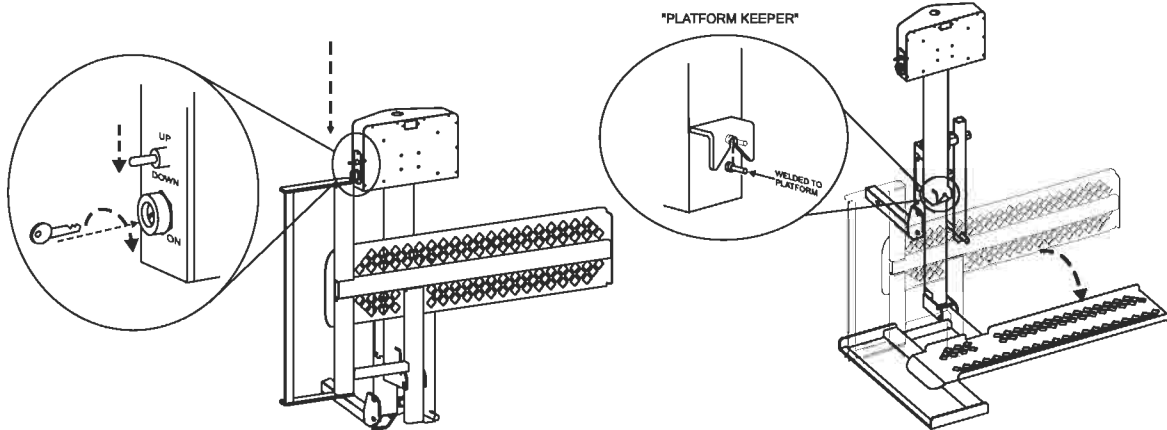

1 Insert Key and switch to "ON" position
Press down on Toggle switch momentarily.

2 Once platform has been lowered at least an inch, unfold the platform. Continue lowering to the ground.

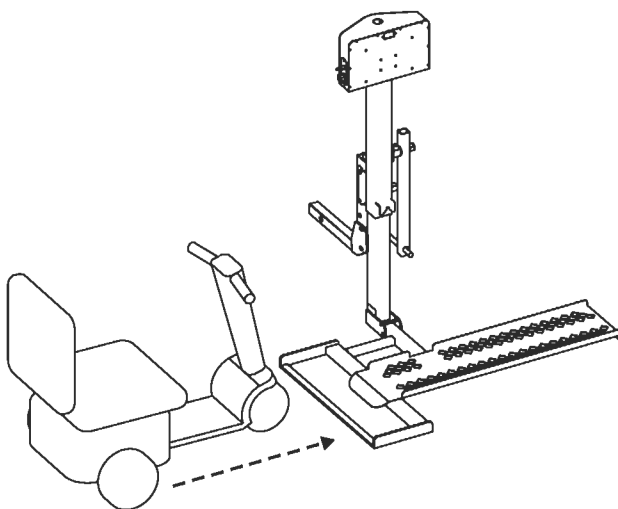

3 Drive scooter onto platform as shown.

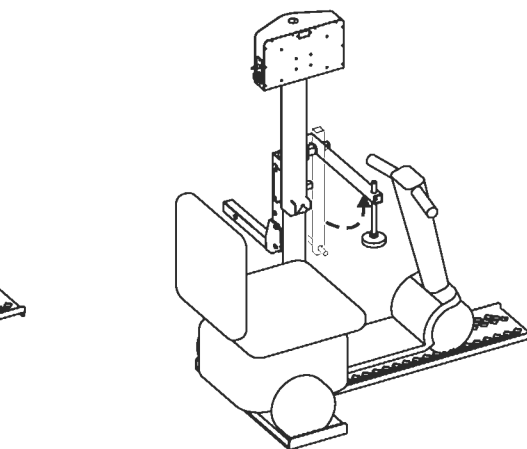

4 Raise hold down arm.

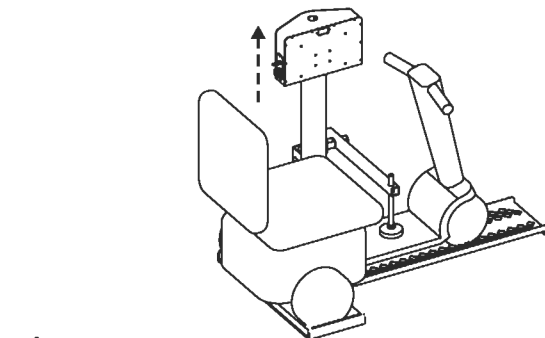

5 Raise platform until hold down foot depresses scooter's deck or until lift's motor ratchets.

To remove the scooter and prepare the lift for unloaded travel, follow above steps in reverse order and reverse the direction of the arrows.

Lift should be raised with the platform folded and until the lift's motor ratchets. Verify that the platform keeper has engaged the platform's pin.

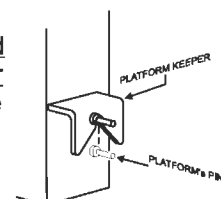

Operation

AL030 LOADING THE WHEELCHAIR

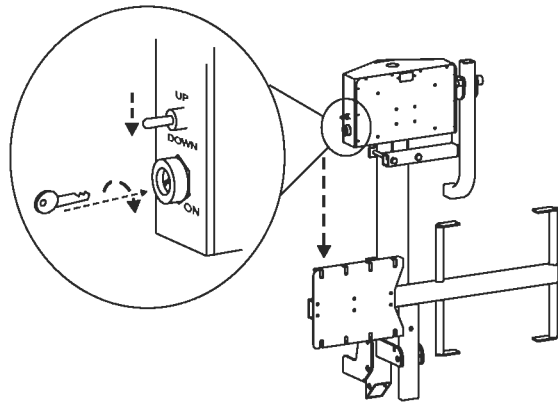

- 1 Insert Key and switch to "ON" position
Press down on Toggle switch momentarily.

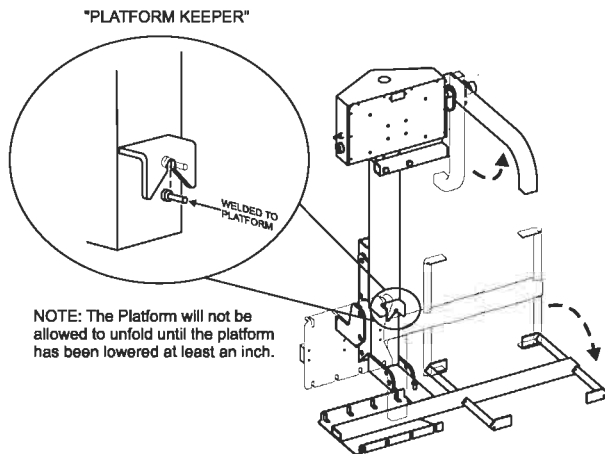

- 2 Once platform has been lowered at least an inch,
unfold the platform. Continue lowering
to the ground. Raise hold down arm.

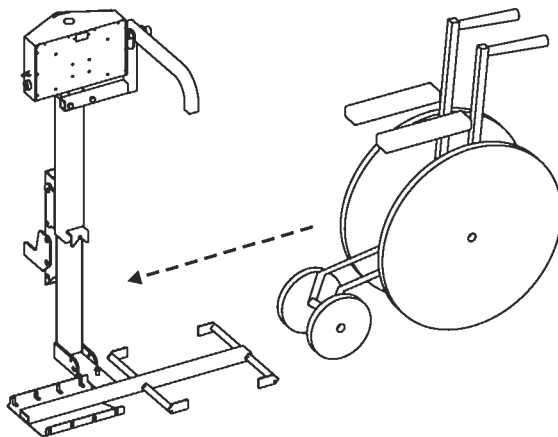

- 3 Roll folded chair onto platform as shown.

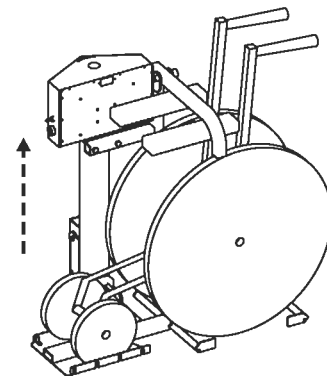

- 4 Raise the lift until hold down arm has
contacted wheelchair's arm rests.

To remove the chair and prepare the lift
for unloaded travel, follow above steps in
reverse order and reverse the direction
of the arrows.

Lift should be raised
with the platform folded
and until the lift's motor
ratchets. Verify that the
platform keeper has
engaged the platform's
pin.

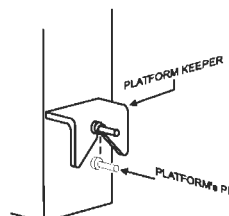

Operation

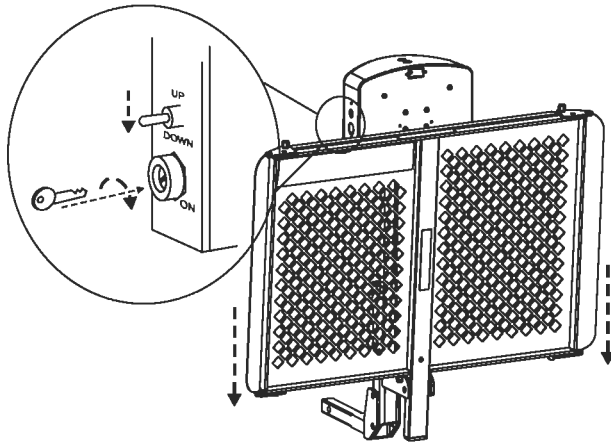

- 1 Insert Key and switch to "ON" position. Press down on Toggle switch momentarily.

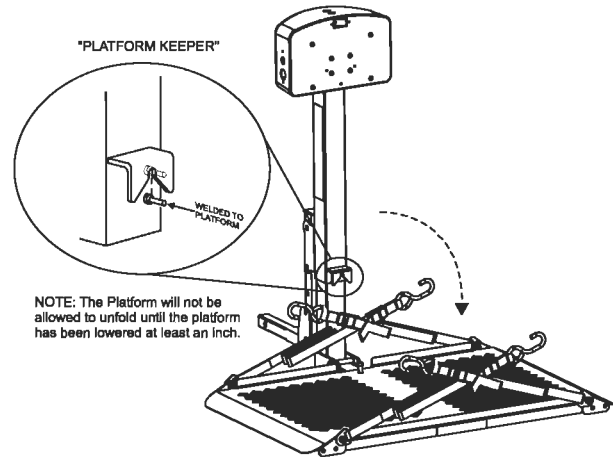

- 2 Once platform has been lowered at least an inch, unfold the platform. Continue lowering to the ground.

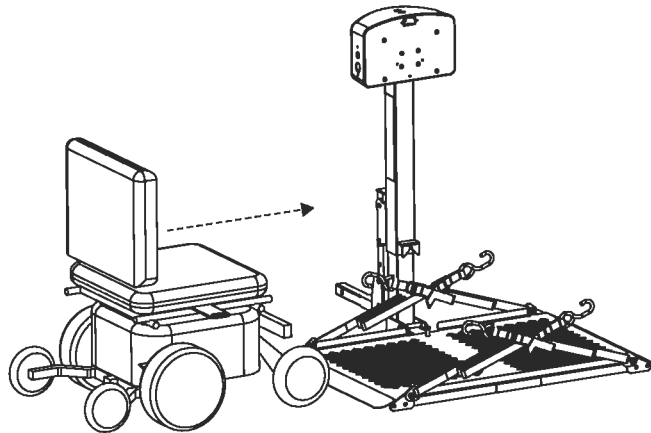

- 3 Drive chair onto platform as shown.

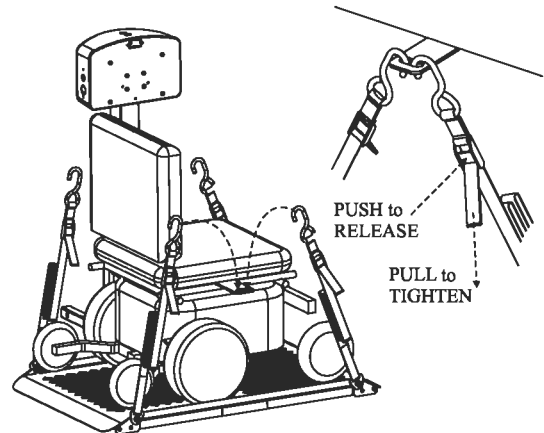

- 4 Strap the chair down using the 4 straps located on each corner of the platform.

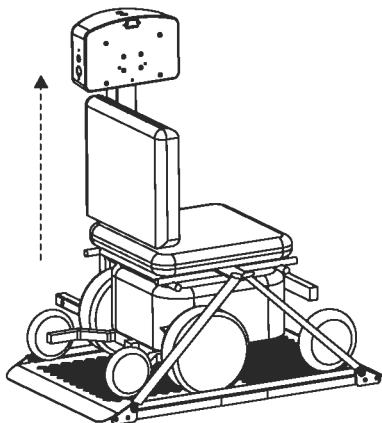

- 5 Raise platform with toggle switch, until motor's ratchet sound is heard.

To remove the chair and prepare the lift for unloaded travel, follow above steps in reverse order and reverse the direction of the arrows.

Lift should be raised with the platform folded and until the lift's motor ratchets. Verify that the platform keeper has engaged the platform's pin.

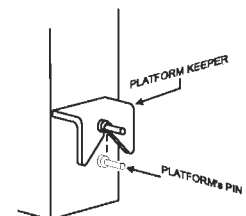

Swing Away

Operating the Swing Away

Many scooter and chair owners require access to the rear of a vehicle. To accomplish this a Swing Away option is added to the lift installation. This allows the complete lift to be conveniently and easily swung away from the back of the vehicle and allow easy access to the trunk or lift gate. The Swing Away option can be purchased from any authorized dealer and added at any time.

OPENING THE SWING AWAY:

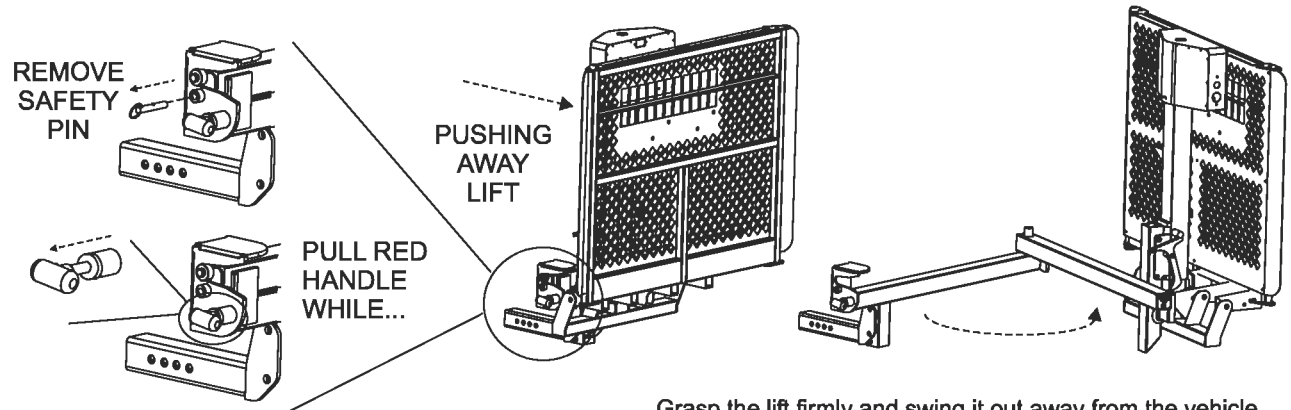

Grasp the lift firmly and swing it out away from the vehicle. The Swing Away can be opened up to 180 degrees from the closed position to allow full access to the rear of the vehicle.

IMPORTANT!! NEVER OPERATE THE SWING AWAY WITH THE CHAIR or SCOOTER ON THE LIFT!!
This will cause damage to the Swing Away, lift and potentially cause damage to the vehicle and the chair!!

CAUTION!! Always insure that the vehicle is on level ground before attempting to open the Swing Away.
Failure to do so may result in the operator losing control of the lift causing damage to persons and property.

CLOSING THE SWING AWAY:

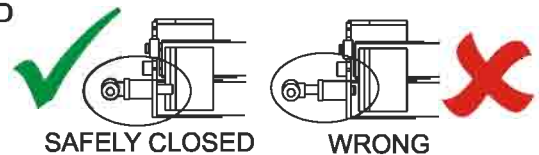
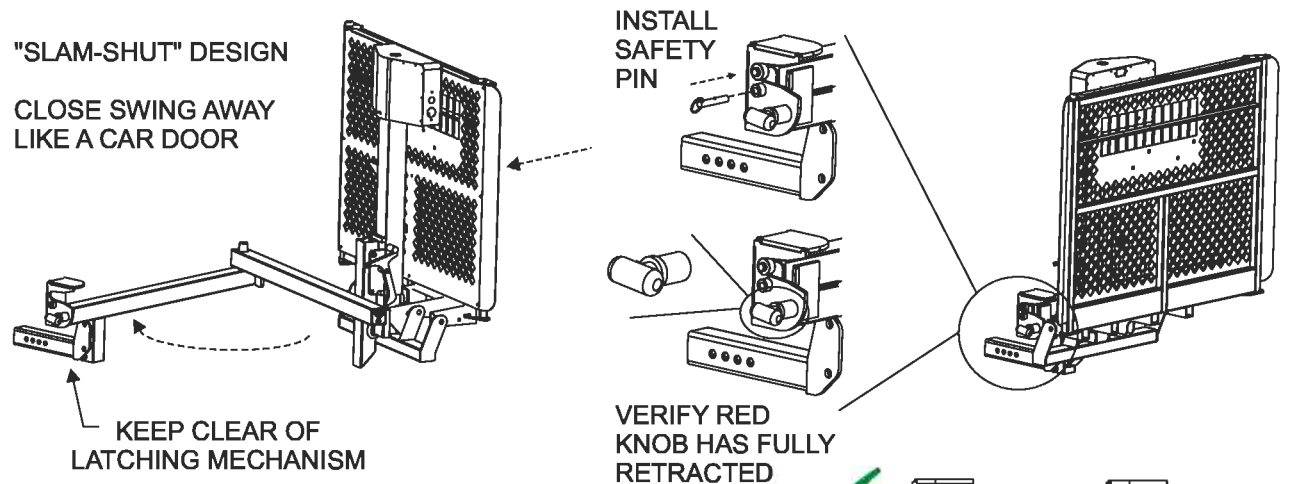

CAUTION!! Always install the safety pin.

Safety & Maintenance

Caution: Keep hands away from **PINCH POINTS**.

As with most mechanical objects, the hinge point of a moving part creates a pinch point. Be sure to not to stick fingers or extremities at or near these points.

Inspect the condition of your lift often. **If any parts are worn or damaged DO NOT USE THE LIFT.** Immediately contact the dealer you purchased the lift from for repairs.

Caution: Keep feet and any other objects out from under the platform as it lowers.

Caution: Some chairs and scooters have pneumatic (air inflated) tires. If your chair/scooter has this type tire, be sure the tires are properly inflated. Improper inflation of the tires will change how the unit fits on the platform and therefore change the amount of clamping force on the chair/scooter.

Caution: Before driving off with your chair or scooter on the lift, make sure that the chair/scooter is firmly held down on the platform.

Caution: When driving with your chair or scooter on the lift, slow down for pot holes, speed bumps, railroad tracks, etc. **Your lift could be damaged by abuse if subjected to excessive loads imposed by rough driving.**

Caution: Do not enter steep driveways straight on. Enter and leave at an angle to the street so that you lift platform does not drag on the ground.

Caution: Do not attempt to move the vehicle with the lift platform in the down position. If moved this way, the lifting mechanism will be damaged.

WARNING! This lift is not meant for human transport. Chair/Scooter must be unoccupied before operating lift.

These lifts are for chair and scooter transport only. **Do not** attempt to transport any other vehicles or materials on the lift other than what it is designed for.

MAINTENANCE:

The Universal outside lift has been designed to be as trouble free as possible for the owner. The maintenance schedule is no exception.

Every 30 days oil the pivot points on all moving parts.

During winter and under dirty and dusty conditions, re-grease the inside square tube every 30 days. Lower the platform to the ground and clean the square shaft with mineral spirits, WD-40 or any good solvent. Once clean, grease the square shaft with a high-grade water-resistant grease, such as boat trailer wheel bearing grease.

NOTE: Your lift was assembled at the factory with Slick 50 "ONE GREASE".

Check for paint chips and touch up any bare metal with a good gloss black enamel or lacquer to inhibit rust. This may be necessary more frequently when subjected to salt air or road salt.

Warranty:

This lift is covered by a three year factory warranty on materials and workmanship. Contact your local dealer for more information.

Troubleshooting Guide

The lift does not operate

Check the power supply. The wiring harness (both wires) must be run directly to the battery. Attaching the black (ground) wire to the frame of the vehicle is NOT considered a reliable ground. Run the lift from a shop battery and not through the vehicle wiring harness. If this solves the problem, check the vehicle wiring harness for bad connections or broken wires. NOTE: Each lift is equipped with a manual motor override located on the top of the motor box. Simply remove the cap and use a 3/8" socket to manually operate the lift. **CAUTION!!** Make sure the key is in the "off" position and no power is connected to the lift. **SERIOUS INJURY MAY OCCUR IF POWER RESUMES DURING MANUAL OPERATION OF THE LIFT!**

The motor does not lift the platform completely when in use.

Check the wire connections at the battery. A poor connection will cause the motor to run slow and have less lifting capacity. Run the lift from a shop battery and not through the vehicle wiring harness. If this solves the problem, inspect the entire length of the vehicle harness for breaks, or worn insulation. A good supply of power will ensure full lifting capacity.

The motor works intermittently

Check the ground and power wire making sure that it is securely attached to the battery of the vehicle. Grounding the lift to any other location may cause loss of ground and intermittent loss of power. Check the wires leading to the toggle switch in the motor housing box. All connections must be securely on the switch.

The platform or hold down arm is not holding upright or is too hard to move.

Check the tension of the pivot point bolts. Too tight, and the movement will be too hard. Too loose and the part will not stay in the desired position. Tighten or loosen bolts until platform and/or hold down arm operates with some resistance.

There is a ratcheting sound when the lift is all the way up or down.

This is a normal sound. It is the clutch activating when the lift reaches the end position. This sound should only occur when the toggle switch is being pressed and the platform is at its highest and lowest point.

The license plate light does not work.

This light runs from the 4 prong trailer plug located on the vehicle wiring harness that powers the lift. Most hitch installers will install this type of wiring when the hitch is installed. If no such plug exists, it may be wired directly to a tail light or license plate light.

What do I do with the extra length of wire leading to the motor of the lift?

This wire is there in case a Swing Away Option is used with the lift. If a Swing Away is not installed, coil the extra wire and zip tie it to the frame of the lift out of the way of any moving parts. We recommend leaving the wire in case a Swing Away is added to the lift at a later time.

The lift does not reach the ground when lowered completely.

Check the attachment of the Hitch Adapter to the Hitch Post on the back of the lift. The normal range of operation for the lift is 5 to 18 inches to the bottom of the hitch. Any higher vehicles will require a custom bracket.

The lift bottoms out when going over bumps or in driveways.

Check the attachment of the Hitch Adapter to the Hitch Post on the back of the lift. The normal range of operation for the lift is 5 to 18 inches to the bottom of the hitch. The lift should be installed at the highest position possible. Enter driveways at an angle

I have lost my keys.

Contact the dealer where the lift was purchased. If they do not have extra keys in stock, they can get them from the manufacturer.