

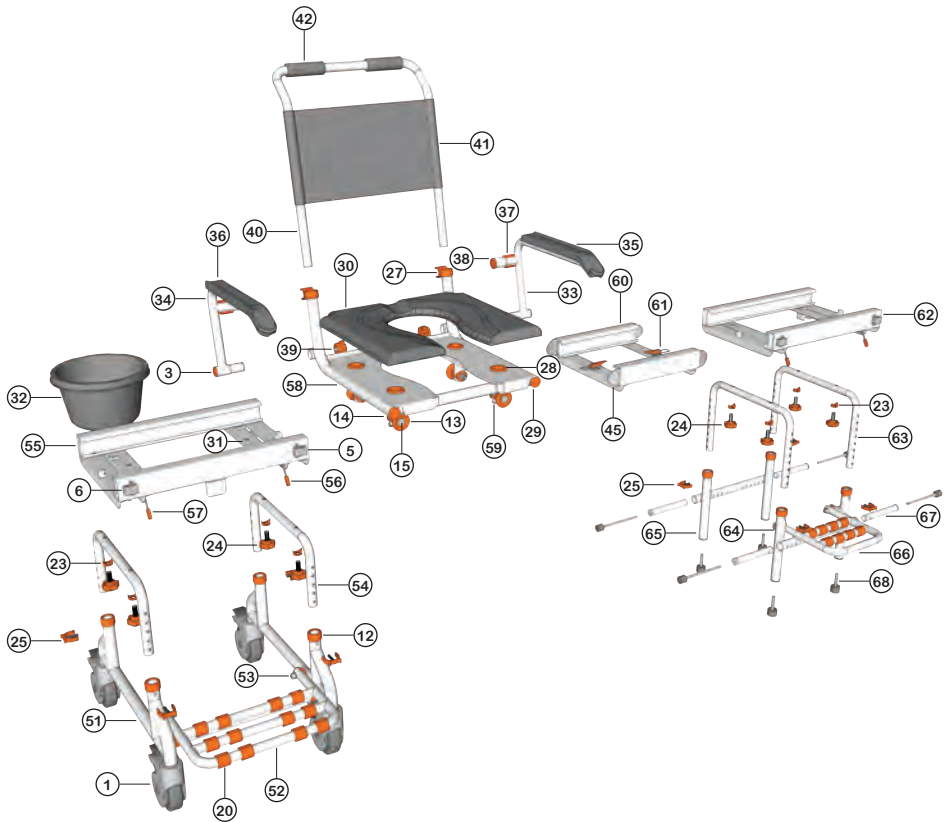

SB2
TubBuddy
Owners Manual

Exploded Parts	3
Parts List	4
TubBuddy Assembly	5
TubBuddy Setup	10
TubBuddy Operation	15
Cleaning + Maintenance	20
Safety Instructions	21
Warranty Information	24
Registration Form	26

exploded parts



See the exploded chair image for the location of parts.

- ① 5" Castor Wheel
- ③ Tube Cap (25mm)
- ⑤ Secondary Brake (Left)
- ⑥ Secondary Brake (Right)
- ⑫ Leg Tube Cap
- ⑬ Track Wheel
- ⑭ Tube Washer (32mm)
- ⑮ Track Wheel Axle (Front)
- ⑳ Foot Rest Grips
- ㉓ Tube Washer (25mm)
- ㉔ Fixing Knob
- ㉕ Securing Clip (Large)
- ㉖ Arm Rest Clip
- ㉘ Cushion Connector
- ㉙ Tube Cap (32mm)
- ㉚ Cushion
- ㉛ Commode Bucket Connectors
- ㉜ Commode Bucket + Lid
- ㉝ Arm Rest (Left)
- ㉞ Arm Rest (Right)
- ㉟ Arm Rest Padding (Left)
- ㊱ Arm Rest Padding (Right)
- ㊲ Arm Rest Lock
- ㊳ Arm Rest Cap
- ㊴ Arm Rest Knob
- ㊵ Back Rest Frame
- ㊶ Back Rest Fabric
- ㊷ Hand Grips
- ㊸ Bridge Tongue (Short)
- ㊹ Rolling Base Legs
- ㊺ Foot Rest (Rolling Base)
- ㊻ Foot Rest Attachment (Nut + Bolt)
- ㊼ Height Adjustment Tubes (Rolling Base)
- ㊽ Rolling Base Track
- ㊾ Primary Brake Lever (Left)
- ㊿ Primary Brake Lever (Right)
- ① Seat Base
- ② Primary Brake Stopper
- ③ Bridge
- ④ Latch
- ⑤ Bath Base Track
- ⑥ Height Adjustment Tubes (Bath Base)
- ⑦ Bath Base Leg (Front)
- ⑧ Bath Base Leg (Rear)
- ⑨ Foot Rest (Bath Base)
- ⑩ Stabilising Tubes
- ⑪ Rubber Feet

step 1

Insert the back rest into the seat base.

Slide the back rest into the seat base until the clip pins click into the holes on the seat base.

The clip pins secure the chair back frame in position.

NOTE

- To remove the seat back press the clip pins in and slide the seat back out of the seat base.

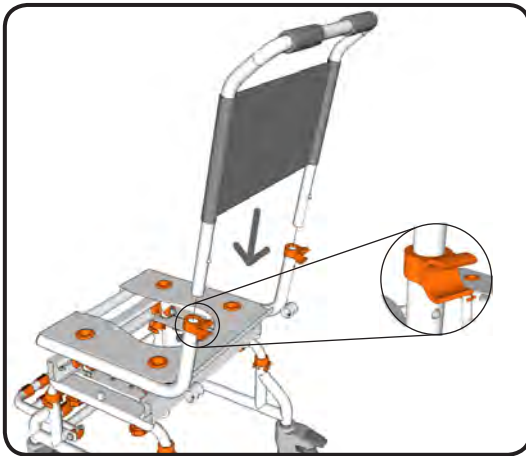

step 2

Insert the arm rests into the sockets on the seat base until the clip pin clicks and locates the arm rests in position.

Screw the arm rest knob into the arm rest to firmly secure the arm rest in position.

Swing the arm rest forward so that it locks into position in the arm rest clip.

Slide the arm rest lock over the arm rest clip to lock the arm rest in position.

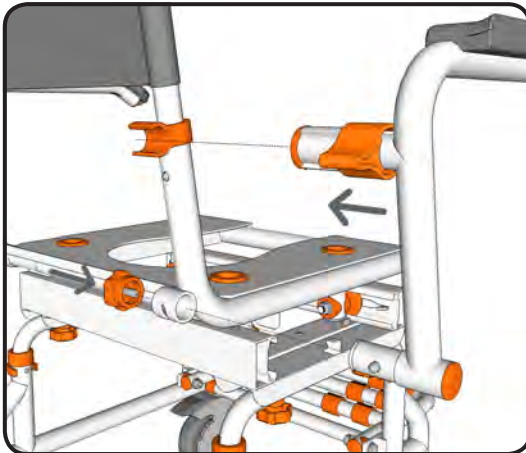

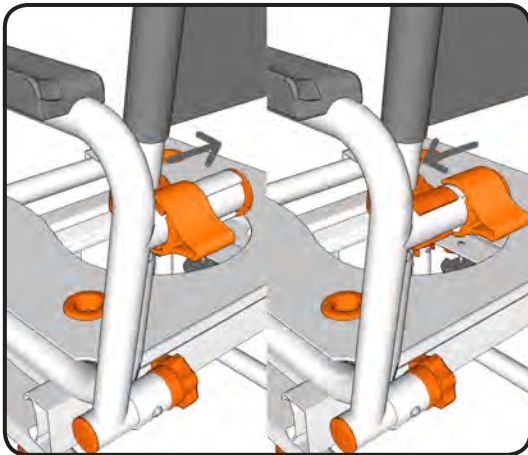

step 3

By sliding the armrest lock you can easily swing the armrest out of the way or secure the armrest in position.

To unlock the armrest slide the armrest lock away from the armrest.

To lock the armrest slide the armrest lock towards the armrest.

NOTE

- The armrest locks should always be used when the armrests aren't in the swing away position.



step 4

The armrests can be easily swung-away when required.

Unlock the armrest by sliding the armrest lock away from the armrest. Once this is done the armrest can be swung away. The clip pin which secures the armrest in position stops the armrest from rotating to far.

NOTE - The armrest locks should always be used when the armrests aren't in the swing-away position.

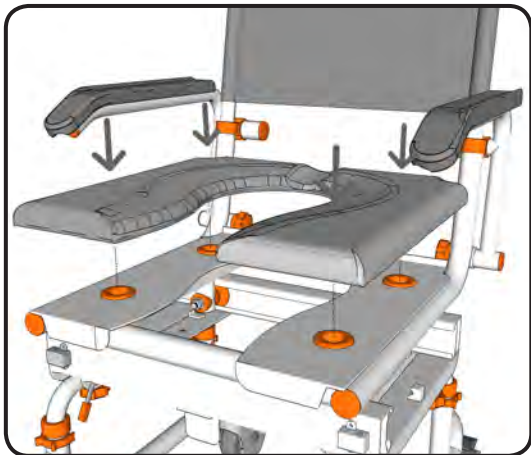

step 5

Ensuring the correct orientation attach the seat cushion to the seat base by pushing the 4 locating lugs on the underside of the cushion into the connectors on the seat base.

Firmly press the cushion into position so that the 4 locating lugs are securely located in the connectors.

NOTE

- To remove the cushion, carefully remove one lug at a time from the connectors until all 4 locating lugs are removed.

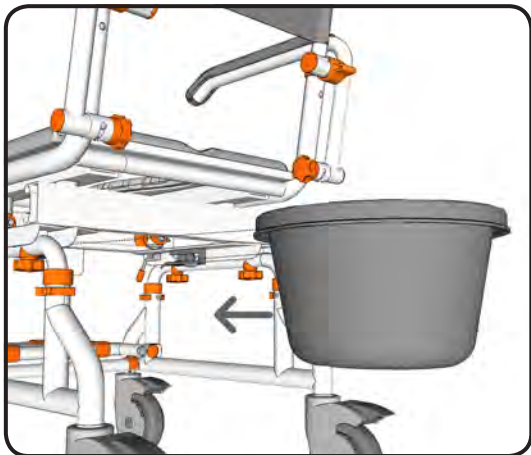

step 6

Rotate the chair so that you have easy access to the underside of the seat base.

From the back of the chair slide the commode bucket into the 2 brackets on the underside of the seat base.

Ensure the commode bucket is pushed in far enough that the brackets securely hold the commode bucket in position. The commode bucket should be centred under the opening in the cushion.

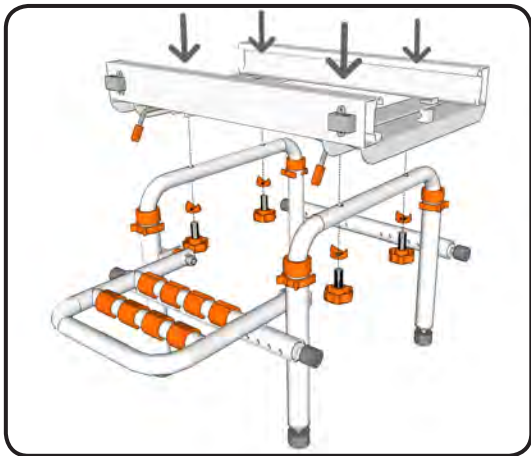

step 7

Using the grooves on the underside of the bath base track as a guide, place the bath base track onto the height adjustment tubes.

Position the bath base track on the height adjustment tubes so that the 4 threaded holes on the wheeled base track are aligned with the 4 holes on the top of the height adjustment tubes.

Secure the bath base track in position by screwing 1 large fixing knob and tube washer through each of the 4 holes in the height adjustment tubes and into the threaded holes on the bath base track.

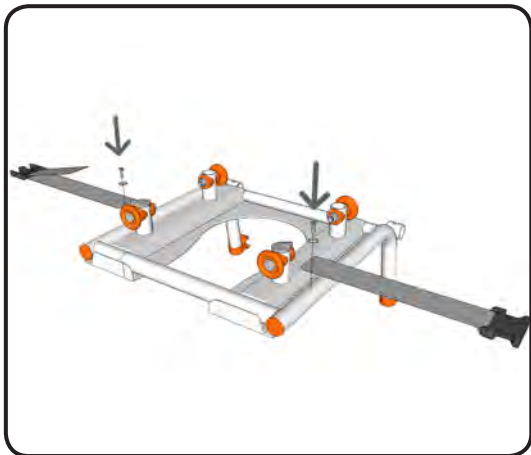

step 8

On the underside of the seat base there are 4 attachment points for the lap belt.

Unscrew the provided screws and washers from the front attachment points on the underside of the seat base.

Choose the attachment points you prefer for your lap belt.

Slide the washer onto the screw and then insert through the grommet in the lap belt.

Screw the lap belt securely into position.

step 9

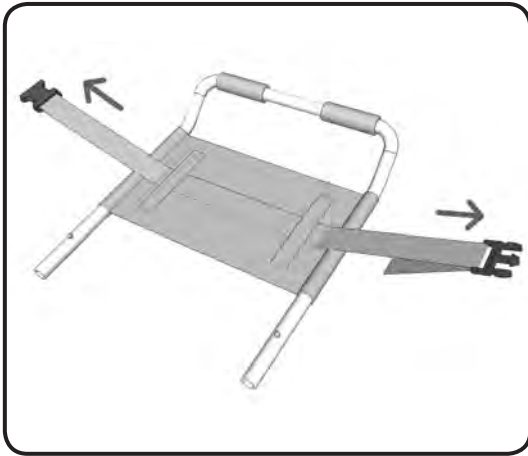

To attach the chest belt rotate the chair so that you have easy access to the back of the back rest.

Slide the chest belt through the 2 attachment loops on the back rest.

Before use adjust the length of the chest belt to suit the user.

step 1

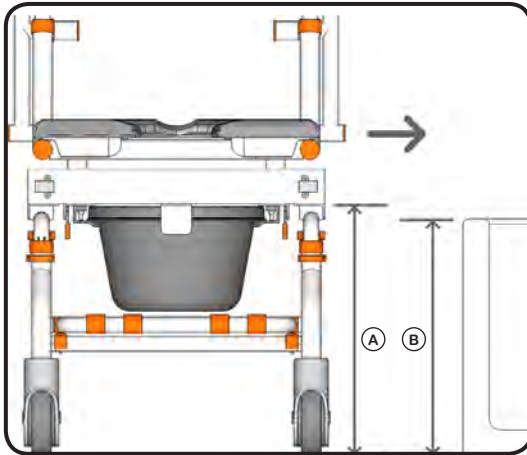

Align the side of your chair with the threshold of your bath.

Check to ensure that the height of the bottom of the wheeled track (A) is higher than the bath threshold (B).

If required the height of the wheeled track can be raised or lowered depending on the bath threshold height.

NOTE

- Each height adjustment hole raises the wheeled track 1".

step 2

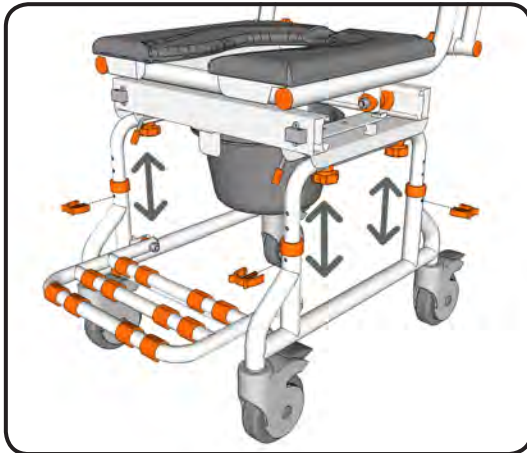

To adjust the seat height remove the securing clips and slide the height adjustment tubes up or down to the required height.

Secure both height adjustment tubes at the required height using 1 large securing clip on each base leg.

NOTE

- Each height adjustment hole raises the seat base 1".
- Check to ensure all securing clips are fully inserted.
- Ensure both height adjustment tubes are aligned at the same height.

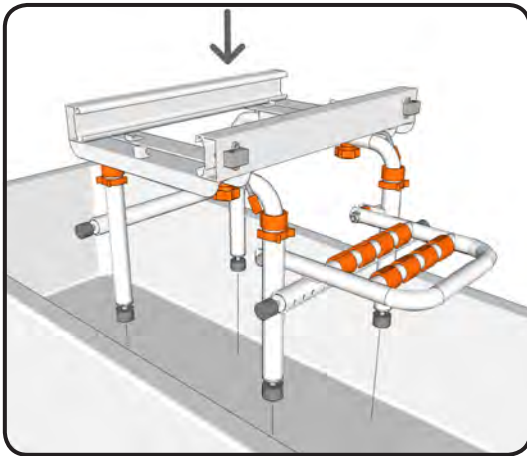

step 3

Place the assembled bath base into your bath.

NOTE

- When positioning the bath base ensure it is located so there is enough room to allow the chair to transfer freely without hitting any other obstructions.

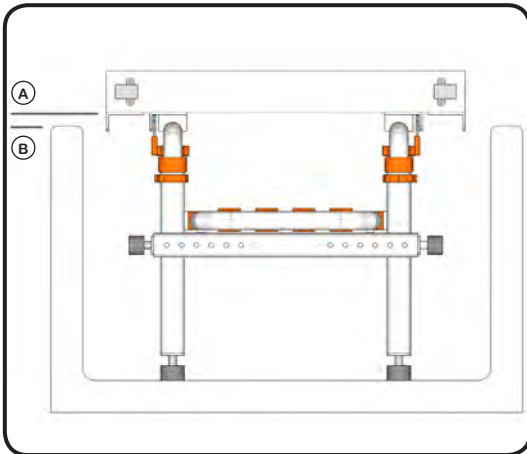

step 4

Check to ensure that the height of the bottom of the bath base track (A) is higher than the bath threshold (B).

If required the height of the bath base track can be raised or lowered depending on the bath threshold height.

NOTE

- Each height adjustment hole raises the bath base track 1".

step 5

Align the bridge with the bath base and insert the tongues into the bath base.

Firmly push the tongues on the bridge into the bath base so the secondary brakes are pushed out of the way.

Secure the bridge to the bath base using the latch in the centre of the bridge track.

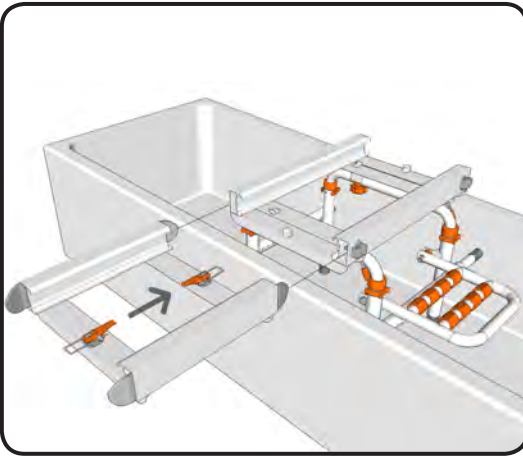

step 6

Align the side of your chair with the bridge which is connected to the bath base.

Firmly push the wheeled base onto the tongues on the bridge so the secondary brakes are pushed out of the way.

Secure the bridge to the bath base using the latch in the centre of the bridge track.

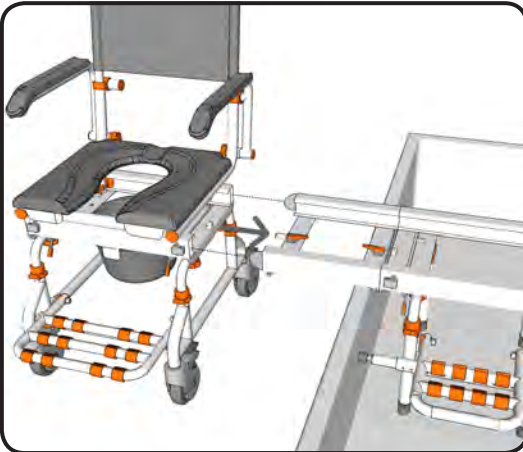

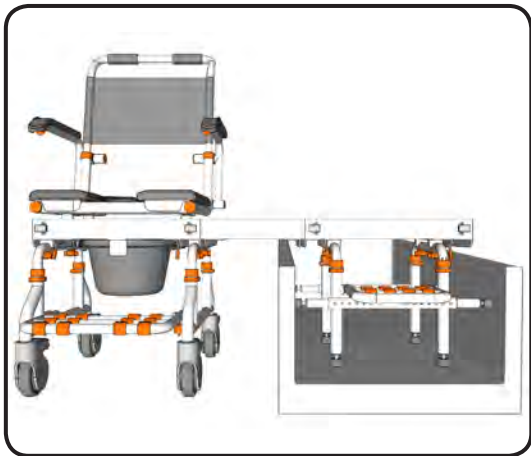

step 7

The wheeled base, bridge and bath base should now be securely connected together using the latches.

Before continuing with the setup it is important to ensure that the tracks are level horizontally.

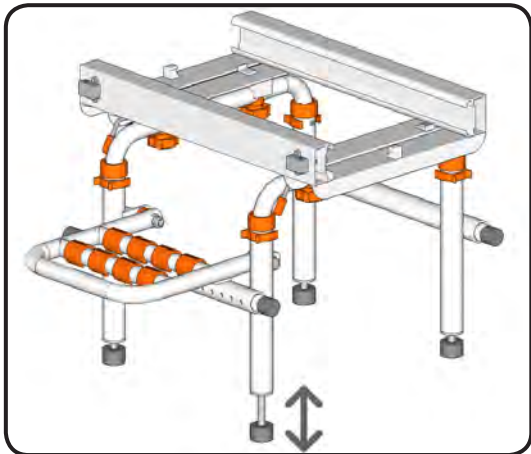

step 8

If the tracks are not level horizontally, adjust the height of the bath base until the tracks are level.

To do this screw the thread on the rubber feet up or down depending on which way the height needs to be adjusted.

NOTE

- Do not unscrew the thread more than 1".
If you require more height, raise the bath base track by adjusting the height adjustment tubes up or down.

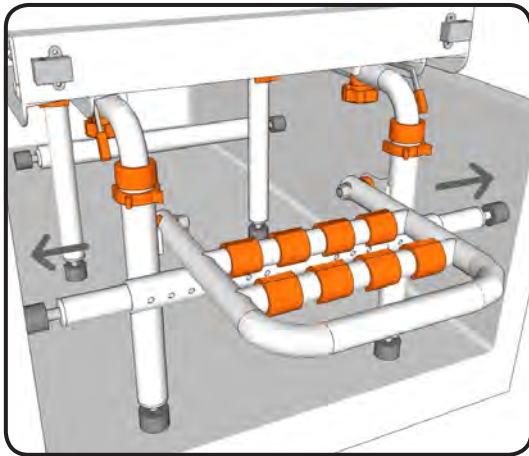

step 9

With the bath base placed in the bath secure it in position by adjusting the stabilising tubes.

Press the clip pin in on the stabilising tube and slide outwards to the correct position. For smaller adjustments unscrew the rubber stopper to firmly secure the bath base.

step 1

Securely attach the bridge to the bath base using the latches. Next securely attach the bridge to the wheeled base using the latches.

NOTE

- Ensure all latches securely 'snap' into the locked position. Ensure you lock all castor wheels before beginning the transfer. Always disconnect the bridge from the base that the chair is located on (bath base or wheeled base). If you leave the bridge attached it prevents the secondary brake from operating correctly.

step 2

To lock the castor wheels press down firmly on the end of brake with your foot. This will lock the castor so that it will not move or rotate.

To unlock the castor wheels press down firmly on the front of the brake with your foot. This will allow the castor to move freely again.

NOTE

- The castor wheels should always be locked when performing transfers. The castor wheels can be rotated forward to make the chair more stable.

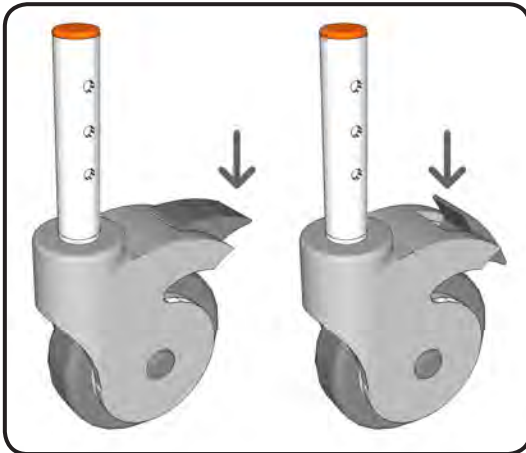
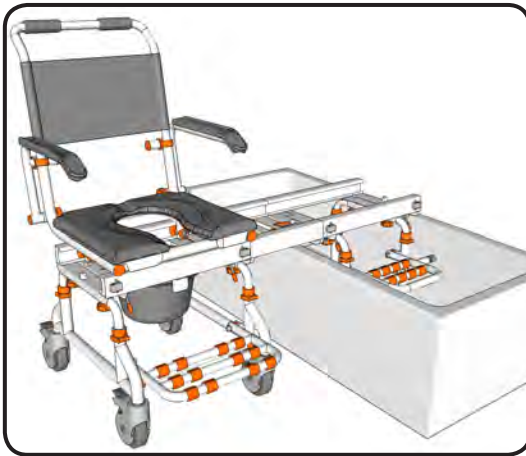

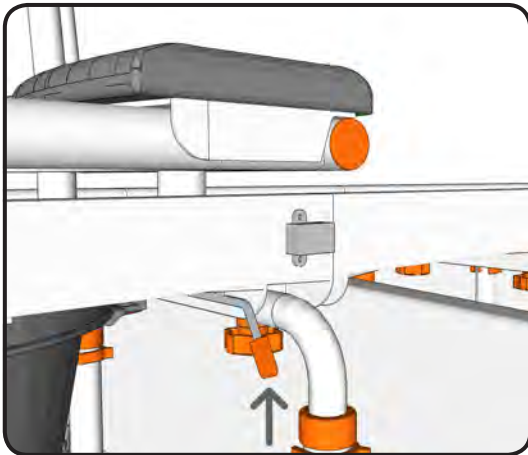

step 3

With your TubBuddy assembled you are now ready to transfer the chair into the bath.

Lift and hold the primary brake lever to release the chair. The primary brakes are located on each side of the wheeled and bath base tracks at the front.

Once the chair has begun transferring you can release the primary brake. The primary brake will drop back into the correct position.

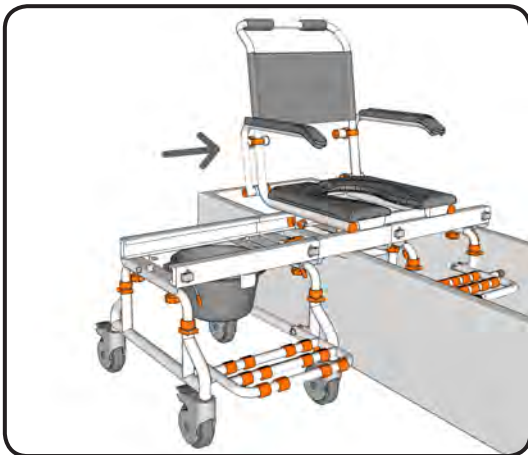

step 4

Transfer your TubBuddy from the wheeled base onto the shower base.

Ensure the chair is transferred all the way onto the bath base and primary brake clicks to secure the chair in position.

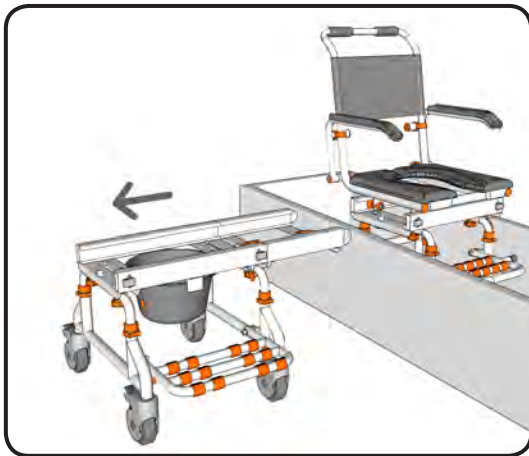

step 5

With your Tubbuddy secured in position on the bath base remove the bridge and wheeled base.

Release the latch which connects the bridge to the bath base and roll the wheeled base and bridge away. If space is limited release the latches on the bridge to remove the bridge from the wheeled base.

NOTE

- Never attach the bridge to the bath base without the wheeled base attached when the chair is on the bath base.

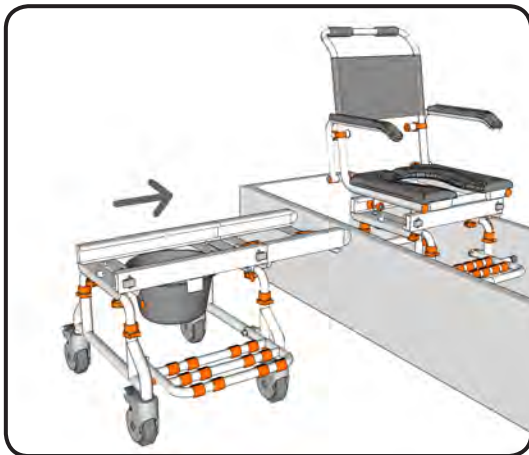

step 6

Reconnect the bridge to the bath base and secure in position with the latches. Reconnect the wheeled base to the bridge and secure in position with the latches.

NOTE

- Ensure all latches securely 'snap' into the locked position.
- Ensure you lock all castor wheels before beginning the transfer.
- Never attach the bridge to the bath base without the wheeled base attached.

step 7

To transfer your Tubbuddy back to the wheeled base lift and hold the primary brake lever to release the chair. The primary brakes are located on each side of the wheeled and bath base tracks at the front.

Once the chair has begun transferring to the wheeled base lift and hold the primary brake lever to release the chair. The primary brake will drop back into the correct position.

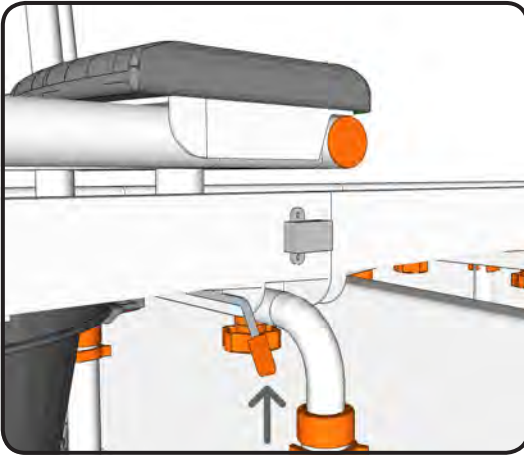

step 8

Transfer your Tubbuddy from the bath base onto the wheeled base.

Ensure the chair is transferred all the way onto the wheeled base and primary brake clicks to secure the chair in position.

NOTE

- Ensure all latches securely 'snap' into the locked position.
- Ensure you lock all castor wheels before beginning the transfer.

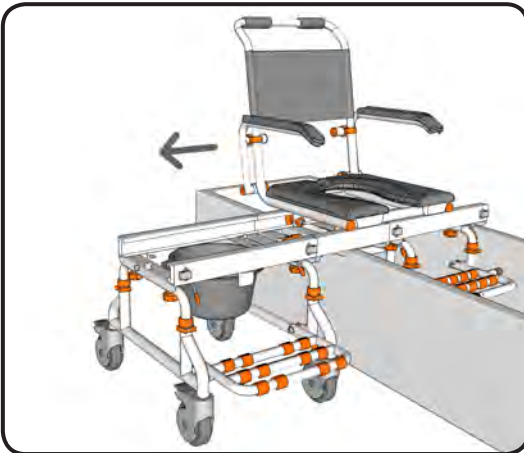

step 9

Ensure the primary brake securely locks your Tubbuddy in position on the wheeled base before disconnecting the bridge.

Unlock the brakes on the castor wheels. Release the latches which connect the bridge to the wheeled base and roll the wheeled base away.

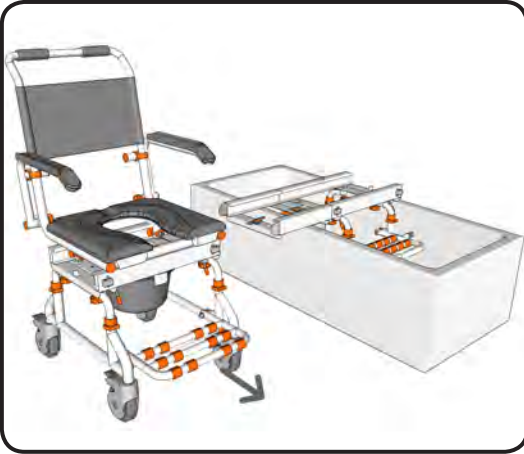

cleaning + maintenance

It is recommended that your shower chair is serviced annually by your Showerbuddy Dealer or an authorised, competent service agent, in addition:

1. Regularly inspect all parts of the chair for defects. Any defective part should be removed promptly.
2. Clean the seat using a damp cloth and a mild cleanser. Always read the manufacturers instructions prior to applying the cleanser.

When using Sodium Hypochlorite (Bleach) on the seat, a solution of 0.1% Sodium Hypochlorite should have no adverse effects on the cleaning of chairs. However, when using a solution of 1.0%, care should be taken to rinse the chairs thoroughly with clean water after application. Over a period of time bleaching may occur, but the integrity of the product will remain unaffected.

3. Dry off the shower chair after use.
4. Do not oil or grease any parts.
5. Keep the castors free from lime scale, soap residue and hair by cleaning after use in the shower.

Caring for stainless steel.

Stainless steel has excellent corrosion resistance, but it is not stain or rust proof. Regular maintenance will keep stainless steel clean and free of contaminants. In most applications stainless steel will not rust or stain even after many years of service, but when used in certain environments such as concentrated chlorine or other corrosive elements stainless steel requires proper care and maintenance. Do not leave stainless in contact with iron, steel or other metals.

1. Clean stainless steel frequently with soap and water. Any cleaner safe for glass is usually safe for stainless steel; apply with a cotton cloth.
2. Use a coating such as a good wax to help safeguard the stainless steel.
3. Remove discolouration or rust spots as soon as possible with a brass, silver or chrome cleaner. Irreversible pitting will develop under rust that remains on stainless steel for any period of time. Apply a mild cleaner such as Ajax or an equivalent with a wet cotton cloth in the direction of the grain of the finish. Rinse thoroughly and wipe dry. Do not use abrasives such as sandpaper or steel wool on stainless steel.
4. Do not clean with mineral acids or bleaches.
5. Do not store near any chlorine product.

safety instructions

Safety Warning!

Failure to comply with these safety instructions may result in injury or damage!

It is important that the user(s), and/or the caregivers of the user(s), learn how to safely operate the Showerbuddy shower chair.

The following must be read before use of the Showerbuddy shower chair to ensure the safe operation of your Showerbuddy shower chair:

The Owner(s) Manual must be read and understood before using the Showerbuddy shower chair. If you don't understand any parts of the Owner(s) Manual, clarification should be sought prior to using the product.

For further clarification of any part of the Showerbuddy Owner(s) Manual call your local dealer or visit the website below.

www.showerchairs.co
www.myshowerbuddy.com

Transfers to and from the Showerbuddy shower chair can be dangerous. Consult a physical or occupational therapist to ensure safe and reliable transfer techniques are practiced. Individuals who have not learned these skills must have assistance during transfers.

Do not use the Showerbuddy shower chair for any application outside of the manufacturers intended use, this can result in damage to the shower chair and components. Not complying with the manufacturer's instructions can result in injury to the user(s) or caregiver. Showerbuddy will not be held responsible for any injury or damage resulting from the misuse or inappropriate operation of the Showerbuddy shower chair.

If any part of the Showerbuddy shower chair requires maintenance please don't hesitate to contact your dealer. Any problems that could affect the safe operation of the chair **MUST** be attended to immediately.

Safety instructions:

The **MAXIMUM** weight of any Showerbuddy shower chair user(s) is: 350lbs (160kg)

ALWAYS ensure that your Showerbuddy shower chair is capable of maneuvering over the surfaces that will be encountered during day to day use, prior to operating the shower chair with any user(s).

ALWAYS lock the Showerbuddy shower chair 5” castor wheels when the chair is stationary. To do this step-on the levers which activates the wheel locks.

DO NOT lean forward or sideways out of the Showerbuddy shower chair as this may cause the chair to tip.

DO NOT wheel the Showerbuddy shower chair down an incline without a caregiver who can control the chair during its descent.

DO NOT use the Showerbuddy shower chair castor wheel locks as brakes when travelling down inclines.

DO NOT position the Showerbuddy shower chair sideways on a slope as this could cause it to tip.

Important!

Although every effort has been made by the Showerbuddy team to ensure the stability of the Showerbuddy shower chairs during use, it is important to recognize that the most dangerous part of using any shower chair is the transfer. If you are unsure of how to perform transfers in a way that can be repeatedly performed safely, then contact a physical or occupational therapist who is familiar with transfer techniques and options.

The wheel locks on the castors are designed to prevent the castor wheels from rotating when the shower chair is stationary in use. These **DO NOT** and **CANNOT** prevent the wheels from sliding if the floor is slippery. A slippery floor can be caused by dust, water, soap or any substance that doesn't allow the tires (tyres) to grip. **Transfers should never be attempted with the Showerbuddy shower chair positioned on slippery surfaces** since the wheel locks can only prevent the wheels from rotating. It is recommended that transfers be performed on clean, dry non slippery surfaces.

Transferring onto a Showerbuddy Shower Chair – always lock all castors in their outward position (front castors positioned in the forward and out position / rear castors positioned to the rearward and out position) for maximum chair stability.

Never use the foot rests to assist with transfers. This could cause the chair to tip forward. The footrests should be swung away or removed entirely during transfers to provide unobstructed access to the shower chair.

The fasteners – the nuts, bolts, washers – should be checked periodically to ensure that they are securely fastened. All nuts used on your Showerbuddy shower chair are lock nuts. Lock nuts that are removed for any reason should be replaced rather than re-used. Your dealer should be called to check the fasteners and other components at least once per year.

All Showerbuddy shower chairs are supplied with chest and lap restraining straps which ensure the correct and safe operation of the shower chair for both the user(s) and the caregiver. It is important that these straps are used every time the shower chair is operated. Your Showerbuddy shower chair is equipped with fitting points so that these can be easily and effortlessly attached.

Important!

ADJUSTMENTS SHOULD NEVER BE ATTEMPTED WITH THE USER(S) IN THE CHAIR!

Your authorized Showerbuddy dealer can help you with any adjustments you may want to make on your Showerbuddy shower chair or can provide clarification on any of the information contained herein.

All castor wheel shafts must be adjusted to the same height. Never attempt to change the frame angle by changing the castor position. If the castor wheels are uneven this will cause the chair's stability to be compromised and may result in tipping.

warranty information

2 Year Limited Warranty

Showerbuddy warrants our Showerbuddy Transfer Systems and all Showerbuddy products for **two years** from the date of purchase by the consumer. The warranty will only become active once the consumer submits the warranty registration card to the company with a copy of the purchase receipt. This warranty covers any defects in materials and workmanship on all Showerbuddy products except those listed in the Warranty Exclusion below:

Warranty Exclusions

- Product or parts failure from normal wear and tear
- Damage caused by failure to adhere to the Owner's Manual
- Damage from improper installation, use or repair
- Brake line that operates the handbrake / tilt mechanism on tilting chairs (SB2T and SB3T)
- Improper use of the hand ratchet that is used in adjusting the neck support / adjustment
- Seat cushions and arm rests

Limitations

- The warranty is VOID if the original serial number tag is removed or altered
- The warranty is VOID if the unit sustains damage from unnatural causes
- The warranty is VOID if the unit is used to hold more than the weight limit of 350lbs (160kg)
- The warranty is VOID if the unit has been subjected to neglect, improper maintenance, storage, cleaning or operation as defined in the Owner's Manual
- The warranty is VOID if the unit is modified without Showerbuddy's written consent
- This warranty applies to the original purchaser only, from the date of the purchase, provided a registration card has been submitted to the company within 60 days of purchase.

Your Responsibilities

- If your unit requires warranty service, please contact the dealer from which you purchased the Showerbuddy unit.
- If you do not receive satisfactory dealer service, contact Showerbuddy at the address below.
- Do not return the unit to Showerbuddy without first obtaining a Return Authorization Number from Customer Service
- A defective unit must be shipped to Showerbuddy within 14 days of issuance of a Return Authorization Number by Customer Service

Our Responsibilities

- Showerbuddy's sole responsibility is to repair or replace, at our discretion, the covered components of the unit. This is the exclusive remedy for consequential or incidental damages.
- Upon pre-approval, Showerbuddy may provide exchange services for Warranty returns. Under this program, a refurbished Showerbuddy unit may be shipped after the return of the defective unit. The exchange unit may contain used parts that meet Showerbuddy quality standards. This program is provided at the sole discretion of Showerbuddy. The original warranty term will not be extended due to such a unit exchange and a return unit will become the property of Showerbuddy.

For all USA & Canada Warranties

Register online at: www.myshowerbuddy.com/resources/register

Or you can fax or email it to us.

Showerbuddy LLC
12405 Montague Street
Pacoima, CA 91331
U.S.A

Email: info@myshowerbuddy.com
Phone: (877) 7MY-BUDDY (769-2833)
Fax: (888) 312-3645

For all Other Countries Warranties

Register online at: www.showerchairs.co/resources/register-product

Or you can email it to us.

Showerbuddy Global Limited
PO Box 494
Waikanae 5250
New Zealand
Email: info@showerbuddy.co.nz
Phone: (+64) 21 449-806

registration form



Register your Showerbuddy
Thank you for purchasing a Showerbuddy product!!

About You

Salutation

Name

First

Last

Your Date of Birth

Month

Day

Year

Address

Street Address

City

State / Province

Zip / Postal Code

Country

Phone

Email

About Your Product

Type of Product Purchased

Serial Number of Product

Under the Seat

Name of Dealer You Purchased From



Please send your completed Registration Form to one of the addresses below.

For all USA & Canada Warranties

Register online at: www.myshowerbuddy.com/resources/register

Or you can fax or email it to us.

Showerbuddy LLC
12405 Montague Street
Pacoima, CA 91331
U.S.A

Email: info@myshowerbuddy.com
Phone: (877) 7MY-BUDDY (769-2833)
Fax: (888) 312-3645

For all Other Countries Warranties

Register online at: www.showerchairs.co/resources/register-product

Or you can email it to us.

Showerbuddy Global Limited
PO Box 494
Waikanae 5250
New Zealand

Email: info@showerbuddy.co.nz
Phone: (+64) 21 449-806



USA & Canada Enquires

Showerbuddy LLC
12405 Montague Street
Pacoima, CA 91331
U.S.A
Email: info@myshowerbuddy.com
Phone: (877) 7MY-BUDDY (769-2833)
Fax: (888) 312-3645

www.myshowerbuddy.com

International Office

Showerbuddy Global Limited
PO Box 494
Waikanae 5250
New Zealand
Email: info@showerbuddy.co.nz
Phone: (+64) 21 449-806

www.showerchairs.co



**Designed in
New Zealand**



All ShowerBuddy products are CE, TUV, ISO9001 and TGA (Australian Government Department of Health and Ageing Therapeutic Goods Administration) certified.

Copyright © 2009 by Showerbuddy Global Limited, PO Box 494, Waikanae, 5250, New Zealand.

e: info@showerbuddy.co.nz, t: +64 21 449 806.

All rights reserved