

Oxford® /Hoyer®

Oxford®/Hoyer® Journey User Instruction Manual & Warranty

To avoid injury, read user manual prior to use.

Oxford®/Hoyer® Journey Manuel de l'utilisateur et garantie

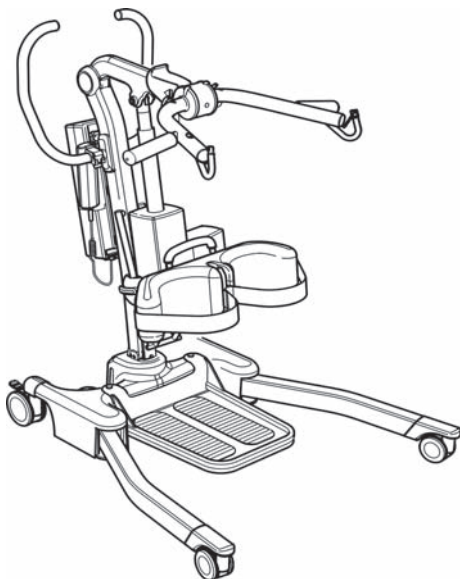
Afin d'éviter tout accident, veuillez lire attentivement la notice avant utilisation.

Oxford®/Hoyer® Journey Manual de Instrucciones y Garantía para el Usuario

Para evitar posibles daños, lea previamente el manual de usuario.

Oxford®/Hoyer® Journey Benutzerhandbuch und Garantie

Um Verletzungen zu vermeiden, lesen Sie bitte die Gebrauchsanweisung vor der ersten Benutzung.



 Joerns
Healthcare

Redefining patient handling

Manufacturer's Contact Details

Oxford®

EUROPE

Joerns Healthcare Ltd

High Street, Wollaston, Stourbridge,
West Midlands DY8 4PS

ENGLAND

+44 (0)1384 44 66 22

Fax: +44 (0)1384 44 66 01

www.joerns.co.uk

Hoyer®

USA

Joerns Healthcare Inc

5001 Joerns Drive, Stevens Point
Wisconsin 54481-5040

715-341-3600

800-826-0270

Fax: 800-457-8827

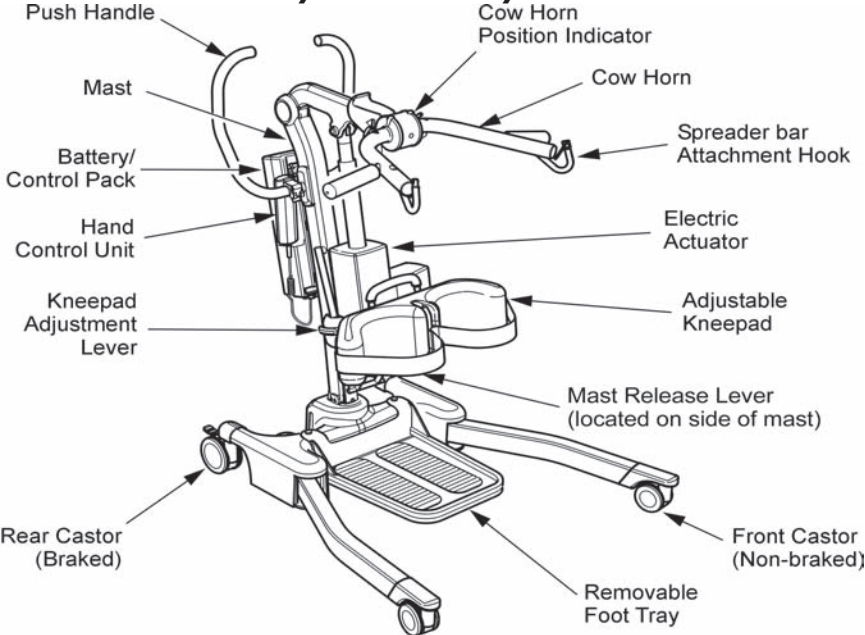
www.joerns.com

Contents

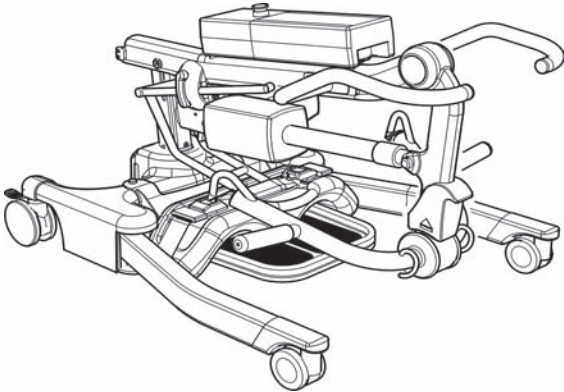
1. The Oxford/Hoyer Journey Patient Lift.....	3
2. Introduction: About Your Lift.....	4
3. Assembly & Commissioning Instructions.....	5
4. Sling Guide	10
5. Lifting With Your Oxford/Hoyer Journey	12
6. Operating Instructions.....	14
7. Safety Precautions.....	17
8. Charging Instructions.....	19
9. Maintenance Schedule & Daily Check List.....	21
10. Technical Specifications.....	23
11. Warranty	26



1. The Oxford/Hoyer Journey Patient Lift



READY FOR USE POSITION



STORAGE POSITION

2. Introduction: About Your Lift

The Oxford/Hoyer Journey is an electrically operated patient lift. Each Journey lift is fully assembled, load tested and certified before being packed/shipped.

The packing consists of a strong, purpose built carton to ensure the safe arrival of the lift.

A number of documents are supplied in a wallet, and packed with each lift and should be kept safely for future reference:

- TEST CERTIFICATE
- USER MANUAL
- DEALER GUARANTEE CARD (Europe only)
- CUSTOMER SATISFACTION CARD (Europe only)
- PACKING CHECK LIST

The TEST CERTIFICATE is an important document and will be required for your insurance records. It is valid for six months but after it has expired the lift should be inspected and serviced as per the maintenance schedule.

Your authorised dealer can carry out servicing and periodic testing for those countries where this is a requirement (Europe). Please ensure your lift is included in their maintenance schedule. If you are at all unsure what your local market servicing requirements are, please check with your dealer, a local government agency and/or Joerns Healthcare.

The CE mark:



The Oxford/Hoyer Journey carries the CE mark and complies with the following EC directives:

- Medical Device Directive (93/42/EEC)
- EMC Directive (89/336/EEC) (Electrics only)
- Low Voltage Directive (73/23/EEC) (Electrics only)



3. Assembly & Commissioning Instructions

CARTON CONTENTS

Place the carton in a clear working area and open carefully. The carton contains:

- OXFORD/HOYER JOURNEY LIFT
- BATTERY PACK
- WALLET CONTAINING DOCUMENTS
- CHARGING LEAD
- HAND CONTROL
- DESK TOP CHARGER/STAND

⚠ WARNING

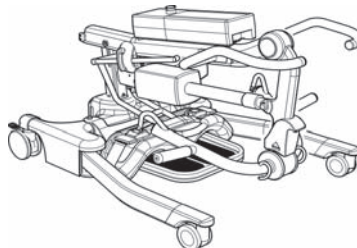
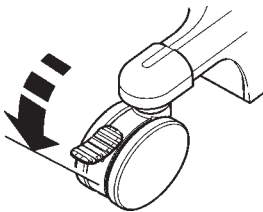
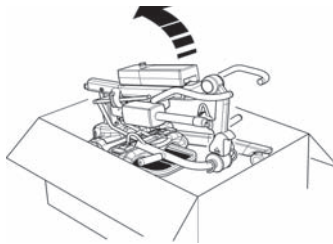
The Oxford/Hoyer Journey is heavy and will need to be lifted with care. You may need assistance to lift the Oxford/Hoyer Journey from the carton.

ASSEMBLY

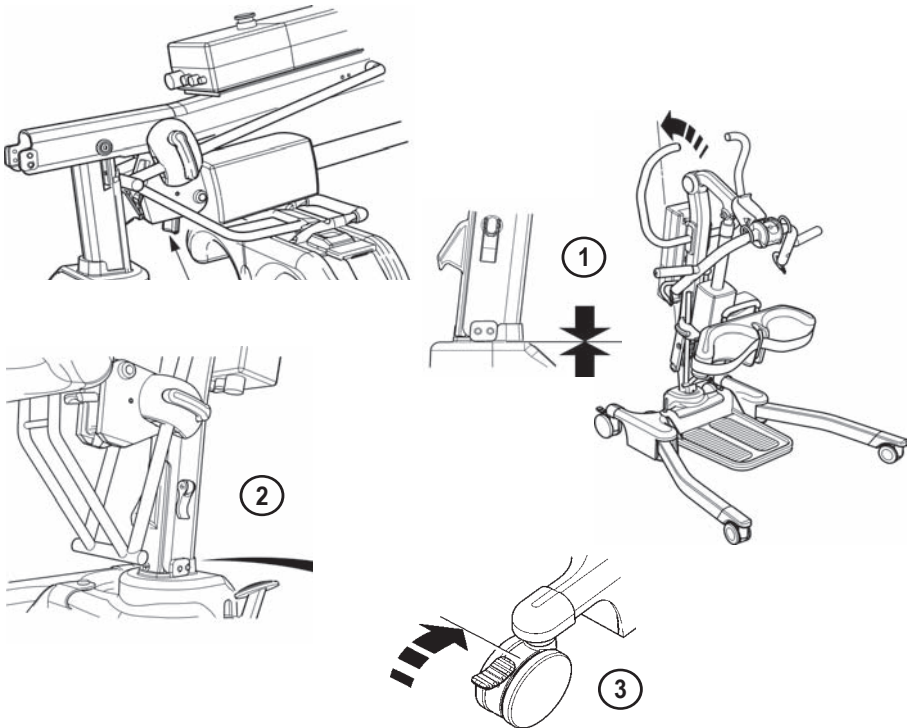
The Oxford/Hoyer Journey is delivered in its folded/storage position; the following assembly process demonstrates the 3 easy steps required to take the Oxford/Hoyer Journey from its storage position to its ready for use position. This process is carried out with no additional tools required.

1. Remove all the parts from the carton and place on the floor, taking care to protect the finish from damage.

Lift the Oxford/Hoyer Journey carefully from the carton. Lie the lift flat on the floor and ensure the rear castors are securely locked.



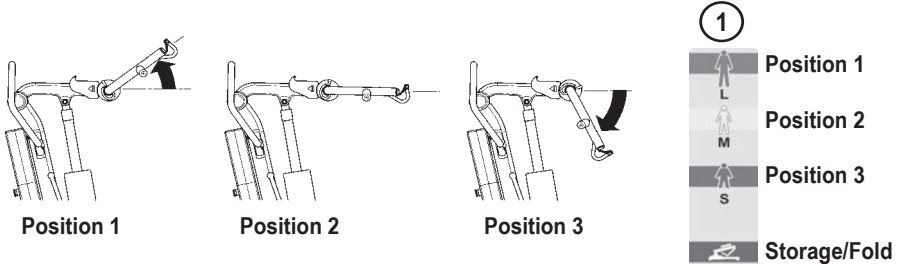
2. To unfold the Oxford/Hoyer Journey into its ready-to-use position, raise the mast assembly upright. This is achieved by pressing the mast release button located under the actuator (as shown). This will release the mast assembly and allow the mast to be raised. Using the top of the push handle, raise the mast to its upright position and locate the mast into the slot (1). Once the mast is firmly located, use the mast locking lever to secure the mast. This is achieved by pushing the mast locking lever down towards the mast surface (2). Finally, release braked castors at the rear and the Oxford/Hoyer Journey is ready for use (3).



SAFETY NOTE: Avoid trapping fingers. Keep fingers away from the end of the mast when inserting into the mast slot. Tighten the mast-locking device, and unlock the braked castors at the rear.



3. Adjust the cow horn mechanism into one of three positions to suit either the patient task and/or environment. To adjust the cow horn, simply pull the trigger backwards towards the rear of the lift while holding the cow horn. Then select the desired position as indicated on the positioning decal (1) and release the trigger to lock. The lift is now ready for operation.

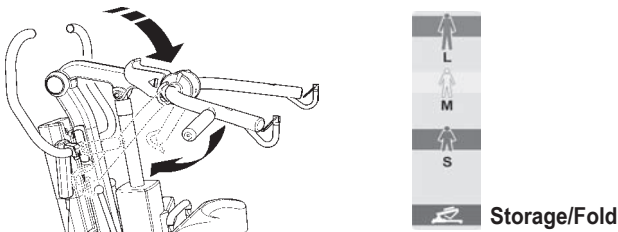


NOTE: See page 12 for cow horn position guidelines.

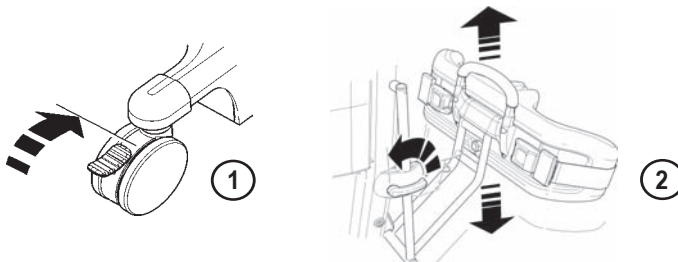
DISASSEMBLY

To disassemble and store the Oxford/Hoyer Journey follow the four easy steps shown below; please note that no additional tools are required.

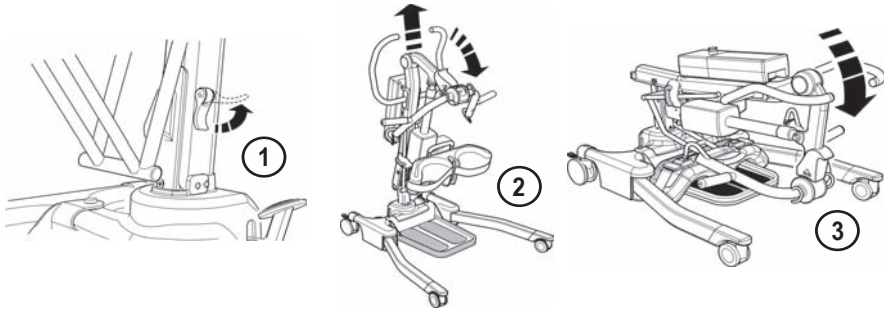
1. Lower the boom into its lowest possible position and adjust the cow horn to the storage/fold position (as shown).



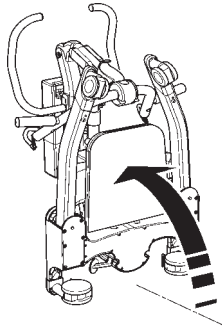
2. Ensure the rear castors are securely locked (1). Raise the knee pad to its upper most position (2).



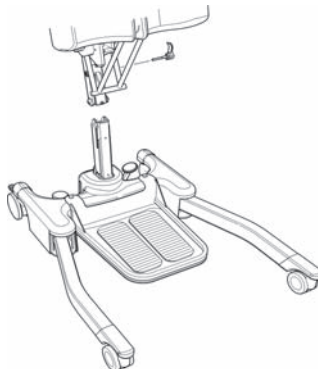
3. Unlock the mast-locking lever by pulling it outwards from the mast (1). Using the push handle lift the mast upwards and then slowly push downwards (2), carefully folding the mast assembly towards the legs until you hear a “Click” (3). The “Click” indicates the mast is now in its locked position.



4. When folded, lift the Oxford/Hoyer Journey upright using the legs and push handle as a guide.



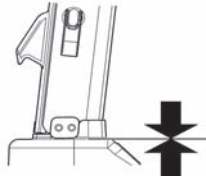
NOTE: If you wish to separate the mast and boom completely from the base and legs, undo the mast-locking lever fully (remove pin assembly from mast) and lift the mast and boom completely free from the base. Be careful not to lose the mast lock lever and location spindle.



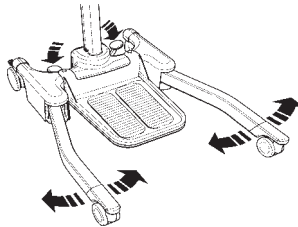
NOTE: Care should be exercised when folding/unfolding the Oxford/Hoyer Journey as there is a possible danger of trapping the fingers etc. Please follow the instructions carefully and ask for assistance if you are unsure of the correct procedure.

ALWAYS CHECK THE FOLLOWING BEFORE OPERATION:

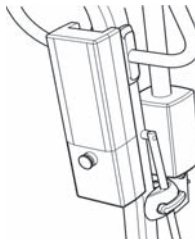
- The mast is fully locked into position (see assembly instructions, page 6).



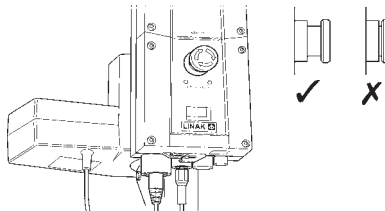
- The legs of the lift open and close freely (Using foot pedals).



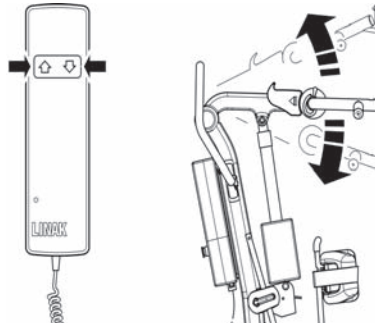
- The power pack is fitted to the lift and the latch holding the power pack in place is fully engaged. A "Click" should be heard when it is in place.



- The red emergency stop button, located on the control box, is in the RUN (out) position.



- The up and down buttons on the hand control lower and raise the boom correctly.



4. Sling Guide

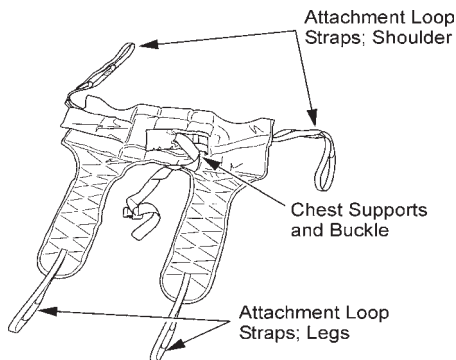
The Oxford/Hoyer Journey is suitable for patients in the SITTING position. The slings suitable for this device are listed as follows:

- * Oxford/Hoyer Transport sling (various sizes available)
- * Oxford/Hoyer Standing sling (various sizes available)

USER GUIDE FOR STANDAID SLINGS

Both the Transport and Standing sling are easy fit slings, suitable for standing and supporting. They are not a general purpose sling. Patients must always be assessed for suitability by a qualified person.

Transport Sling

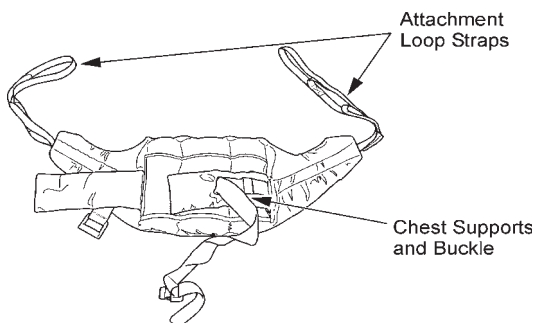


Fitting Instructions

Feed the sling down the back of the patient leaving the top of the commode aperture at the base of the spine. Check the roll part of the sling is square across the patient's back. Attach the support strap around the chest of the patient. This strap need not be tight. It is there to hold the sling in position while attaching the loops to the Standaid. It may be left off altogether if preferred. Ensure patient's arms are on the outside of the sling (refer to Fig. C, page 13).

Raise the patient's leg and feed the leg strap under and up between the legs. Ensure the sling is not twisted or creased under the thigh. Repeat this procedure for the other leg. Attach the loops on the roll parts of the sling to the white hooks at the end of the handgrips. Without crossing the loops on the leg straps, attach to left and right hooks on the lifting fork. You would normally use the middle of the three loops. The patient is now ready to be raised from the seat. Once clear of the seat, the patient will be more comfortable if lowered back in to the sitting position. Joerns Healthcare recommends that slings be checked regularly and particularly before use for signs of fraying or damage. Do not use slings that are worn or damaged.

Standing Sling



Fitting Instructions

Place the sling down behind patients back between base of shoulder blades and bottom of rib cage. Attach the support straps around the front of the patient. This strap need not be tight. It is there to hold the sling in position whilst attaching the sling to the Standaid. It may be left off altogether if preferred. Ensure that the patient's arms are outside the sling (refer to Fig. A, page 13)

NOTE: For detailed fitting instructions, please refer to the user guide supplied with each sling.

⚠ WARNING

Joerns Healthcare recommends that slings be checked regularly and particularly before use for signs of fraying or damage. **DO NOT** use slings that are worn or damaged.

⚠ WARNING

Oxford/Hoyer slings and lifters are not interchangeable with other manufactures products. Using other manufacturers products on Oxford/Hoyer products may be unsafe and could result in serious injury to patient or caregiver.

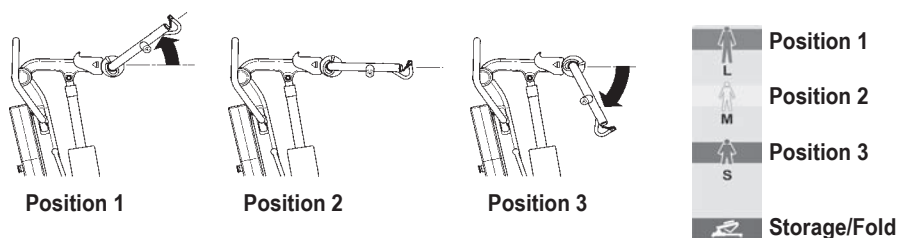
⚠ WARNING

Refer to maximum weight capacity of lift. Sling capacity is limited by the maximum capacity of the lift.

5. Lifting With Your Oxford/Hoyer Journey

The Oxford/Hoyer Journey has an adjustable cow horn. This allows the carer to position the cow horn in a comfortable position to suit the patient or environment. The cow horn has 3 positions. Position 1 is more suitable for a large/taller patient, position 2 is more suitable for a medium/average size patient and position 3 is more suitable for a shorter/pediatric patient or when standing a patient from a low chair. (Please note, these are guidelines only, it may be necessary to adjust according to patient comfort). To adjust the cow horn, simply pull the trigger backwards towards the rear of the lift whilst holding the cow horn. Then select the desired position as indicated by the positioning decal and release trigger to lock. The cow horn has 3 alternative positions for lifting and a further one for the storage/fold position.

Cow Horn Lift Positions



Lifting from a sitting position

Select the most suitable cow horn position to suit the patient or environment. Once complete, position the Standaid so that the patient's feet fit in the foot tray and the knees rest against the kneepad (adjust knee pad accordingly and fit safety belt if required). Attach the loops of the sling to the grey hooks at the end of the Oxford/Hoyer Journey handgrips. The patient's hands should be placed on the handgrips (see Fig A or C). Prior to lifting make a visual check to ensure the loops of the sling are secure and in place. Then, push the UP button on hand control to raise the patient to the standing position (see Fig B or D).

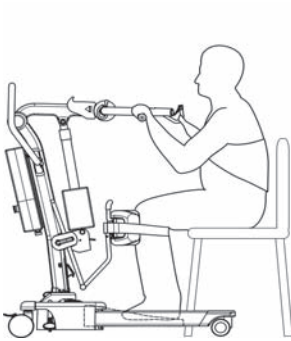
**Standing Sling:**

Fig. A

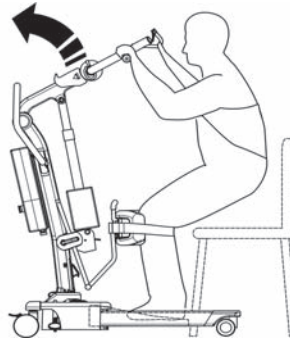


Fig. B

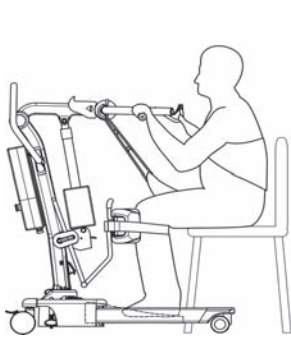
TRANSPORT SLING:

Fig. C

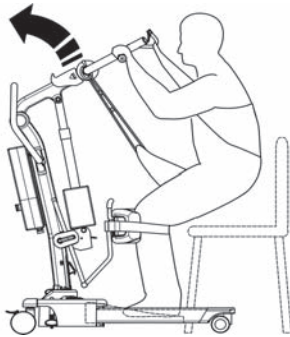


Fig. D

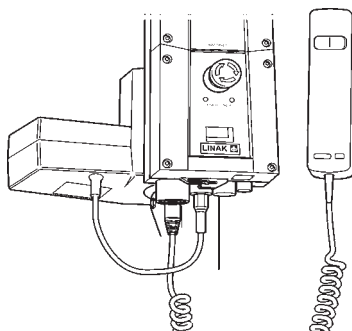
NOTE: Joerns Healthcare recommends a risk assessment be completed before carrying out your lifting operation.

⚠ WARNING

Always utilise the foot tray when standing or seating a patient. Once the patient is in a standing position, the foot tray may be removed for gait training.

6. Operating Instructions

Operating controls for the Oxford/Hoyer Journey lift



Operating Instructions

1. Leg Adjustment

The legs on the Oxford/Hoyer Journey are adjustable for width. The legs can be opened to enable access around armchairs or wheelchairs. For transferring and negotiating narrow doorways/passages, the lift legs should be in the closed position. To achieve the adjustment, the leg adjuster pedal, located at the rear of the base, is compressed right (DOWN) to open the legs outwards and left (UP) to close the legs. The adjustment can be carried out with the patient in the lift, but whether loaded or unloaded the adjustment should be made when the lift is moving.

2. Castors and Braking

The lift has two braked castors, which can be applied for parking. When lifting, the castors should be left free and un-braked. The lift will then be able to move to its natural centre of gravity. If the brakes are applied, it is the patient that will swing to the centre of gravity and this may prove disconcerting and uncomfortable.

3. Raising & Lowering The Boom

A powerful electric actuator that is controlled by a simple hand control unit achieves the movement of the boom. The hand control has two buttons with directional arrows UP and DOWN ↑↓. The actuator stops automatically at its limit of travel in both directions. The hand control plugs into a socket at the base of the control box.

4. Emergency Stop

The red Emergency Stop Button is located on the front of the control box and is activated by pressing it in. This will cut all power to the lift and will only be reset by twisting the button clockwise and releasing.

5. Electrical Emergency Down/Up

Emergency lower (down) and raise (up) buttons are provided at the front of the control box. Inserting a ballpoint pen into the button-highlighted $\uparrow\downarrow$ operates these buttons. This will bring the boom up or down should the hand control fail at any time.

6. Mechanical Emergency Down

In the case of a complete electrical failure the electrical actuator is fitted with mechanical lowering device (RED BOSS). This will only operate when the lift is under load. The device must be pulled upwards to activate, and a slow descent will commence.

7. Batteries

A LOW VOLTAGE ALARM protects the batteries from deep discharge. This will sound when the batteries need recharging and the hand control is being operated. It will not sound independently of the hand control being operated. DO NOT IGNORE THIS WARNING ALARM. Complete the lifting operation and place the battery on charge (see charging instructions). The battery charge level is displayed by the indicator on the control box.

⚠ WARNING

The battery, charger, hand control, control box and actuator should not be opened by unauthorized personnel. (Contact your distributor for warranty and repairs).

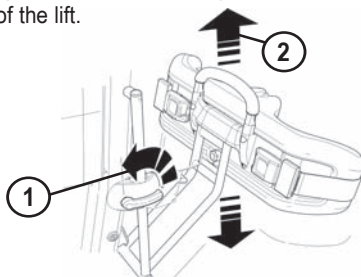
8. Slings

The Oxford/Hoyer Journey is suitable for patients in the SITTING, position. The slings suitable for this device are listed as follows:

- Oxford/Hoyer Transport sling
- Oxford/Hoyer Standing sling

9. Knee pad adjustment

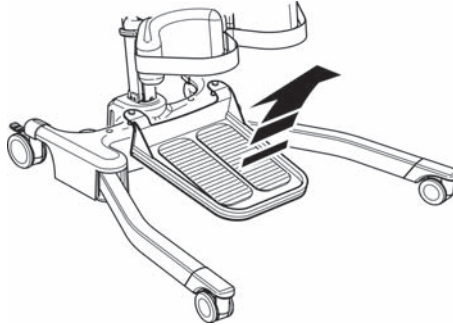
The Oxford/Hoyer Journey has an adjustable kneepad. It is recommended for safety and ergonomic reasons that any adjustment is carried out by holding the top of the adjustment handle. The range of travel is 10.2 inches (260mm). Adjustment is achieved by following two easy steps. STEP 1 turn the kneepad adjustment lever to the left to unlock. STEP 2 either push handle downwards or pull handle upwards to select correct position. Once the ideal position is found, simply turn the kneepad adjustment lever to the right to lock in place, NOTE: the lever can be operated from either side of the lift.



10. Removable footplate

The Oxford/Hoyer Journey has a removable footplate. To remove the footplate, move to the front of the Oxford/Hoyer Journey and lift the footplate upward from the middle of the base assembly.

NOTE: Be careful when removing the footplate from its low-seated position as it is heavy. Always use appropriate moving and handling techniques.

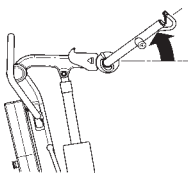


⚠ WARNING

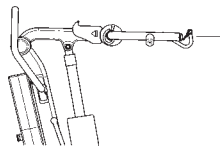
Always utilise the foot tray when standing or seating a patient. Once the patient is in a standing position, the foot tray may be removed for gait training.

11. Adjustable cow horn

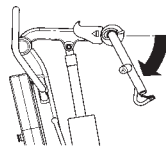
The Oxford/Hoyer Journey has an adjustable cow horn. This allows the carer to position the cow horn in a comfortable position to suit the patient or environment. The cow horn has 3 positions. Position 1 is more suitable for a large/taller patient, position 2 is more suitable for a medium/average size patient and position 3 is more suitable for a shorter/pediatric patient or when standing a patient from a low chair. (Please note, these are guidelines only, it may be necessary to adjust according to patient comfort). To adjust the cow horn, simply pull the trigger backwards towards the rear of the lift whilst holding the cow horn. Then select the desired position as indicated by the positioning decal and release trigger to lock. The cow horn has 3 alternative positions for lifting and a further one for the storage/fold position.



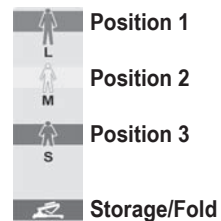
Position 1



Position 2



Position 3



Cow Horn Lift Positions

7. Safety Precautions

Please read and follow the safety precautions listed below. The operation and use of Oxford/Hoyer patient lifts is simple and straightforward. Following these few basic safety precautions will make lifting operations easy and trouble free.

READ AND UNDERSTAND THE USER INSTRUCTION MANUAL BEFORE USING YOUR Oxford/Hoyer Journey

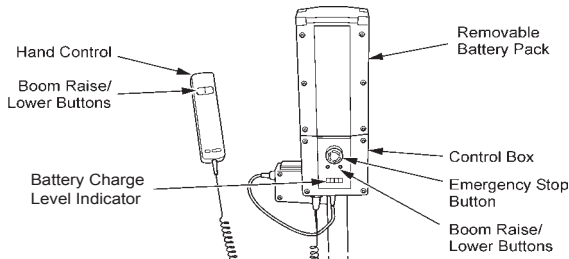
WARNING

- **ALWAYS** plan your lifting operations before commencing.
- **ALWAYS** carry out the DAILY CHECK LIST before using the lift.
- **ALWAYS** familiarise yourself with the operating control and safety features of a lift before lifting a patient.
- **DO NOT** use a sling unless it is recommended for use with the lift.
- **ALWAYS** check the sling is suitable for the particular patient and is of the correct size and capacity.
- **NEVER** use a sling, which is frayed or shows signs of damaged.
- **ALWAYS** fit the sling according to the instructions provided (user instructions).
- **DO NOT** exceed the safe working load.
- **ALWAYS** check the safe working load of the lift is suitable for the weight of the patient.
- **ALWAYS** carry out lifting operations according to the instructions in the user manual.
- **NEVER** disconnect or bypass a control or safety feature because it seems easier to operate the lift.
- **DO NOT** lift a patient with the castor brakes on. Always let the lift find the correct centre of gravity.
- **DO NOT** attempt to maneuver the lift by pushing on the mast, boom or patient.
- **ALWAYS** maneuver the lift with the handle / foot push pad provided.
- **ALWAYS** lower the patient to the lowest comfortable position before transfers.
- **DO NOT** push a loaded lift at speed, which exceeds a slow walking pace (3 Km/hour 0.8 metres/second).
- **DO NOT** push the lift over uneven or rough ground. Particularly if loaded.
- **DO NOT** attempt to push/pull a loaded lift over a floor obstruction.

- **NEVER** force an operating/safety control. All controls are easy to use and do not require excessive force.
- **DO NOT** park a loaded lift on ANY sloping surface.
- **DO NOT** use electric lifts in a shower.
- **DO NOT** charge an electric lift in a bathroom or shower room.
- **DO NOT** lift a patient unless you are trained and competent to do so.
- **DO NOT** use the lift, or allow the lift to be used, for any other purpose.
- **DO NOT** bump the lift down steps, loaded or unloaded.
- **DO NOT** attempt to negotiate a loaded lift on a slope, which exceeds 1:12 (approximately 5 degrees).
- **DO NOT** attempt to negotiate a slope without a second helper being present.
- **DO NOT** use in a wet or corrosive environment such as poolside locations.

8. Charging Instructions

The batteries are located in the power pack and are charged via an off board desktop charger unit.



When the power pack needs charging, it can be removed from the lift and fitted to an off board charging unit. The battery charge level is displayed by the indicator on the control box.

Joerns Healthcare recommends an additional battery pack is purchased, so that one pack can be on charge at all times

1. Remove the power pack from the lift. A simple latch at the top of the power pack retains the pack. Lift the latch and the power pack will be released.
2. Fit the power pack to the charging unit. The location and latching of the power pack to the charger is the same system as used on the lift.
3. Plug the charger mains plug into a suitable mains outlet and switch the mains supply ON. (If applicable).
4. Charging is automatic and will fully charge the batteries over a period of eight to twelve hours. Note: Even if the charger is left plugged in for extended periods it will not allow the batteries to overcharge.
5. To return the lift to service, switch OFF (if applicable) the mains supply and remove the power pack from the charger. Fit the power pack to the lift and make sure the latch holding the pack in place is fully engaged. "Click" in place. The charging of Oxford/Hoyer electric lifts is simple and straightforward, but it is important to follow the charging instructions closely. Please pay particular attention to the following points; they will help you avoid problems with discharged batteries.

⚠ WARNING

The battery, charger, hand control & control box are **NOT** to be opened by unauthorized personnel. (Contact your distributor for warranty and repairs).

⚠ WARNING

DO NOT touch battery/charger terminals.

⚠ CAUTION

KEEP the batteries fully charged. Place the battery on charge whenever it is not in use. If it is more convenient to do so, place on charge every night. The charger will not allow the batteries to overcharge.

⚠ CAUTION

NEVER run the batteries completely flat. As soon as the audible warning sounds, complete the lifting operation in hand and place on charge.

⚠ CAUTION

NEVER store the power pack for long periods without regular charging throughout the storage period.

⚠ CAUTION

ALWAYS make sure the mains power to the charger is switched off before connecting or disconnecting the power pack. (UK EU Requirement).

⚠ CAUTION

NEVER leave the power pack plugged in to the charger with the mains power off. (UK EU Requirement).

⚠ WARNING

Do not charge an electric lift in a bathroom or shower room.

⚠ WARNING

Do NOT leave charger switched on with battery disconnected.

9. Maintenance Schedule & Daily Check List

All Oxford/Hoyer products are designed for minimum maintenance, however some safety checks and procedures are required. Schedules of DAILY tasks are detailed below. Daily checks and a six monthly service, inspection and test will ensure a lift is kept in optimum safe working condition. A list of spare parts is available upon request.

The **LOAD TEST** and certification should only be carried out by qualified personnel or an authorised service agent / dealer.

DAILY CHECK LIST: Joerns Healthcare strongly recommends the following checks be carried out on a daily basis and before using lift.

- **MAKE** sure the lift moves freely on its castors.
- **EXAMINE** the spreader bar (cow horns) is firmly attached to the boom.
- **EXAMINE** the sling hooks and attachment clips on the spreader bar and boom for excessive wear.
- **MAKE** sure the legs open and close correctly.
- **OPERATE** the hand control to confirm the boom raises and lowers satisfactorily.
- **CHECK** the operation of the emergency stop button.
- **EXAMINE** slings for fraying or other damage. **DO NOT** use any sling if damaged.
- **CONFIRM** the lift is not giving a low battery alarm when the hand control is operated. If the alarm sounds, **DO NOT** use and place the battery on charge immediately.

MAINTENANCE, INSPECTION AND TEST

Joerns Healthcare recommends that a thorough inspection and test of the Oxford/Hoyer Journey lift and lifting accessories and slings is carried out on a regular basis.

Inspection frequency varies from country to country so you must check with your dealer or local government agency as appropriate regarding how often an inspection is required. The examination and test should be conducted according to the recommendations and procedures below. Joerns Healthcare recommends maintenance, inspection and certified testing is carried out by an authorized service agent / dealers only.

NOTE: These recommendations are in compliance with the requirements of 1998 No2307 Health and Safety: The Lifting Operations and Lifting Equipment Regulations 1998. This is a UK regulation. Outside the UK please check your local country requirements.

***THESE CHECKS SHOULD INCLUDE:**

	Initially	Before Use	Service Intervals
1. BOOM: Check the attachment of the boom to the mast. Make sure there is only minimal side movement of the boom and the boom is free to rotate on the boom bearing.	✓	✓	
2. MAST: Check the operation of the mast-locking device. Make sure the mast fully engages into the socket.	✓	✓	
3. COW HORN: Check cow horn is engaged and in correct position.	✓	✓	
4. ACTUATOR: The actuator should require no maintenance other than checking for correct operation and listening for unusual noise.			✓
5. KNEE PAD: Check knee pad adjuster is fastened securely.	✓	✓	
6. POWER PACK: Check the function of the emergency stop button and emergency lower.	✓	✓	
7. BATTERIES: The batteries are housed in the power pack and should not require maintenance other than the regular charging as detailed in the charging instructions. Check that the connections remain clean.			✓
8. LEG ADJUSTMENT: Check the legs operate in both full extensions (inward/outward).	✓	✓	
9. CASTORS: Check all castors for firm attachment to the legs. Check for free rotation of the castor and the wheels.	✓	✓	
10. CLEANING: Using a damp cloth, wipe clean with ordinary soap and water and/or any hard surface disinfectant. Harsh chemical cleaners or abrasives should be avoided as these may damage the surface finish of the lift. Avoid wetting any of the electrical parts.		✓	✓
11. LOAD TEST: The load test should be carried out in accordance with the manufacturer's test procedures. It is strongly recommended the testing is carried out by an authorised service dealer.			✓
12. BASE AND WHEELS: Ensure base is even and level (all four wheels are on the floor).	✓	✓	
13. SLINGS: Check for wear and fraying.		✓	
14. LUBRICATION: Lubricate pivot joints with a silicone based oil, including mast and boom connections, pedal assembly, spreader bar joint (only if required).			✓
15. HAND SET: Ensure plugged fully into controller.	✓	✓	



10. Technical Specifications

Safe Working Load	341 lbs	155 kgs
Maximum Overall Length	36.6 inches	1000 mm
Minimum Overall Length	35.2 inches	925 mm
Maximum Overall Height	55.5 inches	1610 mm
Minimum Overall Height	44.1 inches	1130 mm
Maximum Height to attachment point.....	62.0 inches	1550 mm
Minimum Height to attachment point.....	27.4 inches	735 mm
Turning Radius	43.2 inches	1145 mm
Legs Open - External Width	37.4 inches	980 mm
Legs Open - Internal Width	30.1 inches	895 mm
Legs Closed - External Width	26.6 inches	695 mm
Legs Closed - Internal Width	23.5 inches	620 mm
Widest Point (between support handles)	18.8 inches	475 mm
Overall Height of Legs.....	4.5 inches	110 mm
Ground Clearance	1.2 inches	30 mm
Front Twin Castors	3.0 inches	75 mm
Rear Braked Castors.....	4.0 inches	100 mm

Weights

Mast, Base & Boom Assembly	82.4 lbs	37.4 kg
Power Pack	6.2 lbs	2.8 kg
Total	88.6 lbs	40.2 kg
Base Assembly (not inc battery).....	30.2 lbs	13.7 kg
Mast & Boom (not inc battery)	42.3 lbs	19.2 kg
Foot Tray	9.9 lbs	4.5 kg

NOTE: Manufacturing tolerances apply to all dimensions.

ELECTRICAL SPECIFICATIONS:

BATTERIES	24 volt Rechargeable sealed lead acid type
BATTERY CAPACITY	3.2 Ampere hours
CHARGER RATED INPUT	100 - 240 V AC/ 50/60 Hz
CHARGER RATED OUTPUT	29.5 VDC, Max. 19 W

Electric Shock Protection

CHARGER	CLASS II (EN 60601-1)
LIFT INTERNAL POWER SOURCE	

Degree of Shock Protection

CHARGER	TYPE B (EN 60601-1)
LIFT	TYPE B (EN 60601-1)

ENVIRONMENTAL CONDITIONS:

Outside this environment functionality and safety may be compromised.

Operating:

Temperature	5°C to 40°C
Relative humidity	20% to 90% @ 30°C - not condensing

Storage:

Temperature	-10°C to +50°C
Relative humidity	20% to 90% @ 30°C - not condensing

IP RATINGS

Control Box	IP43
Actuator	IP54
Off Board Charger	IP65
Battery	IP65
Handset	IP65

DUTY CYCLES

Actuator	10% (2 min./18 min.)
Charger	Approx. 4 hrs.

ACOUSTICS

A-Weighted sound power level	60 dB (A)
------------------------------------	-----------

KEY SYMBOLS:

The following symbols are used on the charger, control unit and battery:



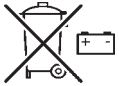
Type B equipment, as per EN 60601-1



Class 2 equipment



The disposal of the charging and control unit should not be mixed with general household



The disposal of batteries should not be mixed with general household waste.



The disposal of electronics should not be mixed with general household waste



For indoor use



ATTENTION, consult accompanying documents.

11. Warranty

Joerns Healthcare has an established network of reputable distributors, dealers and service providers who will be pleased to handle all your purchasing, warranty, repair and maintenance enquiries.

Our products are guaranteed for a period of 24 months from the date of manufacture or 24 months from the date of purchase if commissioned by an authorised dealer. This guarantee covers the lift's major structure, actuator and control box, handset, and battery for manufacturing defects/failures.

We recommend that all of our products are commissioned by your dealer and are supported by them for future servicing. The dealer or distributor operates the warranty programme; so it is important to keep a record of their name, address and telephone number so they can be contacted should any problem arise (Europe only).

Failure to comply to the lift's servicing schedule may result in your warranty being invalid.

If you are in doubt where your lift was purchased, Joerns Healthcare can trace the supplier if you quote the serial number of the lift.

REMEMBER Contact your distributor for purchases, warranty, repairs, servicing and certified maintenance.

Your Dealer/Distributor:





Joerns Healthcare Inc
5001 Joerns Drive
Stevens Point, WI 54481-5040
USA
715-341-3600
800-826-0270
Fax: 715-341-3962

Joerns Healthcare Ltd
High Street, Wollaston
Stourbridge, West Midlands
DY8 4PS
ENGLAND
Tel: +44 (0)1384 44 66 22
Fax: +44 (0)1384 44 66 01