

LUMEX[®]
A Graham-Field Brand

LF1090 BARIATRIC PATIENT LIFT



USER MANUAL

LF1090-INS-LAB-RevC11
© 2011 GF Health Products, Inc.

Read this manual before operating your Patient Lift.

Save this manual for future use.

**The most current version of this manual can be found online at
www.grahamfield.com**

CONTENTS

1	INTRODUCTION.....	3
2	SAFETY PRECAUTIONS.....	4
	WARNINGS.....	4
3	FEATURES.....	6
	LIFT COMPONENTS.....	6
	CONTROL BOX COMPONENTS.....	6
4	HANDLING PROCEDURES.....	7
	SHIPPING AND TRANSPORTATION INSTRUCTIONS.....	7
5	ASSEMBLY INSTRUCTIONS.....	8
	CHARGING THE BATTERIES.....	10
	CHECKING BATTERY CAPACITY.....	10
	ALARM BUZZERS.....	10
6	OPERATING INSTRUCTIONS.....	11
	LIFTING THE PATIENT.....	11
	EMERGENCY RELEASE.....	15
7	CARE AND MAINTENANCE.....	16
	BEFORE EACH USE.....	17
	AT LEAST ONCE A MONTH.....	17
	LUBRICATION.....	17
	CLEANING.....	18
	CARE OF SLINGS.....	18
	MAINTENANCE SCHEDULE.....	18
8	TROUBLESHOOTING.....	19
9	SPECIFICATIONS *.....	20
10	LIMITED WARRANTY.....	21
11	INDEX.....	23

GF Health Products, Inc. is not responsible for typographical errors. Packaging, warranties, products and specifications are subject to change without notice.

Graham-Field and **Lumex** are registered trademarks of GF Health Products, Inc.

1 INTRODUCTION

Congratulations on your purchase of the Lumex LF1090 Bariatric Patient Lift. The following pages will provide you with important safety and operating instructions on the use of patient lifts, slings, and accessories, as well as maintenance and warranty information. Read this manual carefully before operating your patient lift and refer to it as often as needed. Consult your authorized distributor and/or healthcare professional with any questions or concerns regarding safe and effective techniques for operating your patient lift.

DO NOT attempt any transfer without prior approval of the patient's healthcare provider. With their assistance, select the sling that best serves the needs, abilities, comfort and safety of the person being lifted. It is important that you use correct slings adapted to the body shape and weight and ability of the patient and the specific type of transfer needed.

Upon receipt of the patient lift, and prior to each use, inspect it closely to ensure that nothing is damaged, there are no loose or broken parts, that all patient lift parts are in the proper place, etc. Immediately replace any worn or broken components. Your patient lift should receive maintenance on a regular schedule and should be inspected daily for proper operation. Contact your authorized Graham-Field distributor for service and repairs.

Before lifting anyone, thoroughly read the instructions in this manual. Ideally, observe a team of trained experts performing the lifting procedures. The operator should then practice the entire lifting procedure several times with proper supervision and with a capable individual acting as patient. It is extremely important to know how a patient will feel in the patient lift. We suggest that the operator try all the various lifting slings and equipment until the operator is confident with how the patient lift operates. The lifting procedures should be explained to the patient before the actual lifting. Remember that safety requires the constant attention of the lift occupant and the operator. Use extreme care and common sense when operating a patient lift.

This guide covers the use of the LF1090 Bariatric Patient Lift. Keep in mind that the basic safety procedures included in this manual are to be used as a guide only. You may find it necessary to develop your own unique methods for safely utilizing the patient lift. Again, consult your healthcare professionals for their recommendations and never hesitate to ask for their assistance.

Info: Before attempting to assemble the patient lift, refer to the section titled "ASSEMBLY INSTRUCTIONS" contained elsewhere in this manual. Contact your authorized Graham-Field distributor if additional assistance is needed.

Info: In this manual, the person being lifted is referred to as the "patient" or "occupant" and the person operating the patient lift is called the "operator" or "attendant".

Intended use

The Lumex LF1090 Bariatric Patient Lift is intended to aid in the transfer of an individual who is unable to independently transfer between bed, chair, bathtub, wheelchair, and/or commode.

⚠ WARNING: The LF1090 Bariatric Patient Lift is designed for transfer only (to and from bed, chair, bathtub, toilet, wheelchair, commode etc.). This Patient Lift is not intended to be used for transporting or moving a patient from one location to another.

2 SAFETY PRECAUTIONS

IMPORTANT: Before using patient lift, please read and adhere to the following safety precautions and warnings. Failure to do so could result in serious personal injury or damage to your patient lift.

Always consult your healthcare professional to determine safe methods most suitable for your individual abilities. Protect yourself, your attendant and patient lift by having it serviced regularly. If you experience any malfunction, contact your authorized Graham-Field distributor immediately, as a hazardous condition could result, causing personal injury or damage to your patient lift.

Periodic inspection, adjustment and replacement of worn parts are necessary to provide years of excellent service. Refer to *CARE AND MAINTENANCE* section of this manual.

Maintenance **MUST** be performed by qualified personnel **ONLY**.

Significance of safety statements

Please note the following special statements, used throughout this manual, and their significance:

- ⚠ WARNING: Indicates a potential hazard situation or unsafe practice that, if not avoided, could result in death or serious personal injury.**
- ⚠ CAUTION: Indicates a potential hazard situation or unsafe practice that, if not avoided, could result in minor or moderate personal injury.**
- ▲ NOTICE: Indicates a potential hazard situation or unsafe practice that, if not avoided, could result in product or property damage.**

Info: Provides application recommendations or other useful information to ensure that you get the most from your product.

WARNINGS

- ⚠ WARNING: Important! Read and understand these instructions before assembling or using the Lumex LF1090 Bariatric Patient Lift. If you do not understand any part of these warnings, cautions or instructions, contact a healthcare professional for direction in the use of this product. If the Lumex LF1090 Bariatric Patient Lift is not properly assembled, personal injury and damage to the LF1090 could result.**
- ⚠ WARNING: If components are damaged or missing, contact your Graham-Field distributor immediately. DO NOT use substitute parts. Use only Lumex replacement parts. The use of non-Lumex replacement parts could cause personal injury, property damage, and void the warranty.**
- ⚠ WARNING: Unauthorized modification of your patient lift could cause personal injury, property damage, and void the warranty.**
- ⚠ WARNING: The LF1090 Bariatric Patient Lift maximum weight capacity is 600 lb. DO NOT exceed the maximum weight capacity.**
- ⚠ WARNING: GF Health Products, Inc. assumes no responsibility for any damage or injury caused by improper assembly or use of this product.**
- ⚠ WARNING: Check all parts for shipping damage before using. In case of damage, DO NOT USE the equipment. Contact the carrier or your authorized Graham-Field distributor for further instructions.**
- ⚠ WARNING: Patient lift may tip over if used incorrectly. Read and adhere to the operating instructions prior to lifting anyone.**
- ⚠ WARNING: GF Health Products, Inc. strongly recommends that two caregivers take part in the lifting process.**

- ⚠ WARNING: When transferring a patient, always keep the patient centered over the base.**
- ⚠ WARNING: Ensure that lifting sling loops are correctly attached to the hooks to prevent the patient from sliding or falling out of the sling, which could result in personal injury. Never use the patient lift to lift or transfer anything other than a person.**
- ⚠ WARNING: Do not lock the brakes or block the wheels when lifting. The casters must be FREE to roll to allow the patient lift to stabilize itself when the patient is initially lifted from a chair, bed, or any stationary object.**
- ⚠ WARNING: Do not attempt to maneuver the lift by pushing on the mast, boom, actuator, or patient. Always maneuver the lift with the handle.**
- ⚠ WARNING: During lifting or lowering, whenever possible, always keep the patient lift legs in the maximum open position.**
- ⚠ WARNING: To facilitate movement, close patient lift legs before moving the lift.**
- ⚠ WARNING: Replace any worn or broken parts immediately! Torn, cut, frayed, or broken slings can fail, resulting in serious personal injury. Use only slings that are in good condition.**
- ⚠ WARNING: Use extreme care, caution, and common sense when utilizing a patient lift. Special attention must be given to patients who are disoriented and cannot cooperate while being lifted, such as comatose, agitated, spastic, or mentally confused persons. Consult their healthcare professional for assistance in lifting these types of patients.**
- ⚠ WARNING: GF Health Products, Inc. specifically disclaims responsibility for any bodily injury or property damage which may occur during any use which does not comply with federal, state or local laws or ordinances.**

3 FEATURES

LIFT COMPONENTS

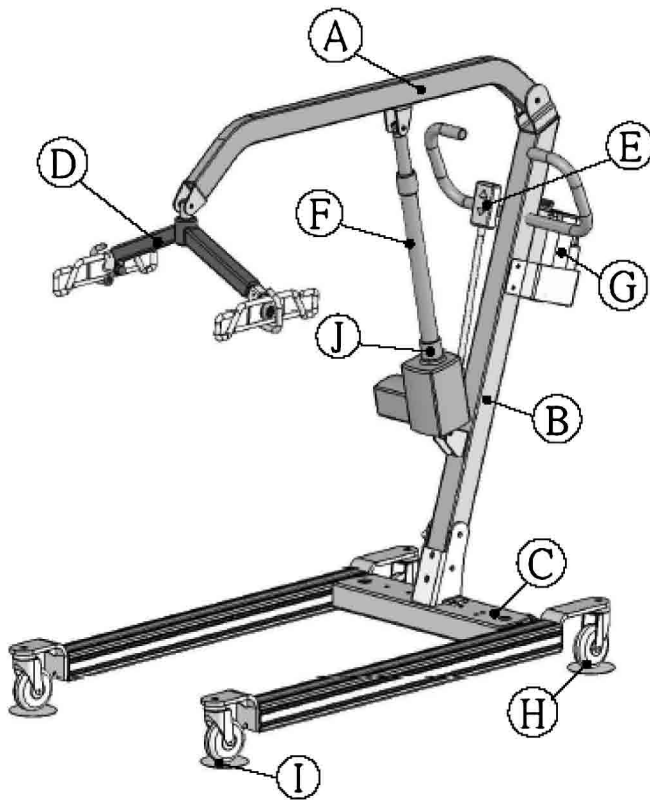

- A. Boom
- B. Mast
- C. Base
- D. Spreader bar
- E. Pendant
- F. Actuator
- G. Control box
- H. Caster brake
- I. Front caster
- J. Emergency Lowering Device

CONTROL BOX COMPONENTS

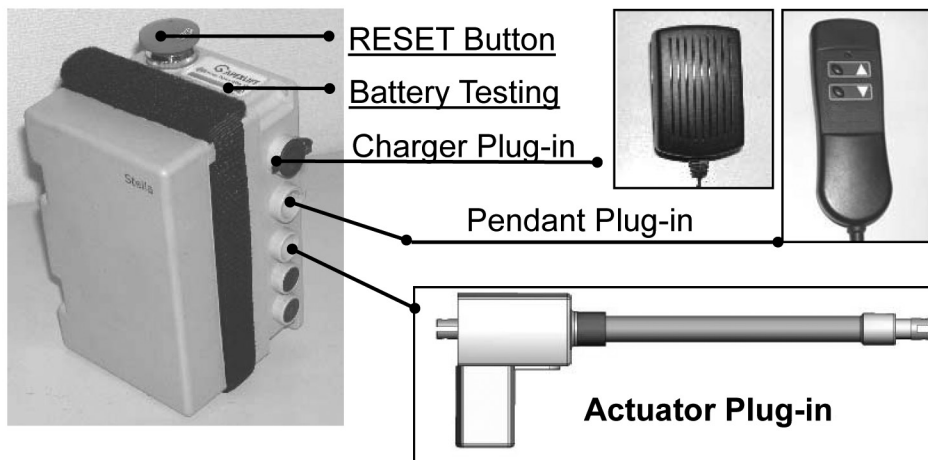

4 HANDLING PROCEDURES

SHIPPING AND TRANSPORTATION INSTRUCTIONS

If the patient lift is to be reshipped by common carrier, it should be packed in the same carton in which it was received.

Unpacking

⚠ WARNING: The lift is heavy. To avoid personal injury, DO NOT attempt to remove the lift from the box without assistance.

1. Check for any obvious damage to the carton or its contents. If damage is evident, notify the carrier or your Graham-Field distributor.
2. Remove all loose packing from the carton.
3. Carefully remove all the components from the carton.

Info: Unless the patient lift is to be used immediately, retain boxes, containers and packing material for use in storing until use of patient lift is required.

Inspection

1. Examine the exterior of the patient lift for nicks, dents, scratches or other damage.
2. Inspect all components.

Storage

1. Store the repackaged patient lift in a dry area.
2. DO NOT place other objects on top of the repackaged patient lift.

5 ASSEMBLY INSTRUCTIONS

⚠ WARNING: The lift is heavy. To avoid personal injury, DO NOT attempt to assemble the lift without assistance.

1. Engage the lift brakes.

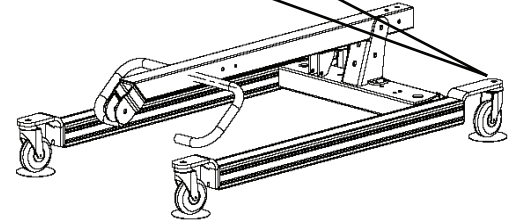
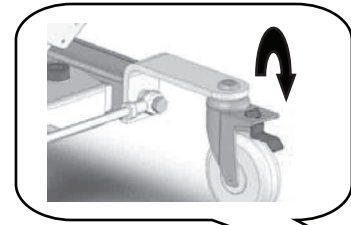

2. Remove the bolts from the bottom of the mast and base.

3. Pull the mast to an upright position.

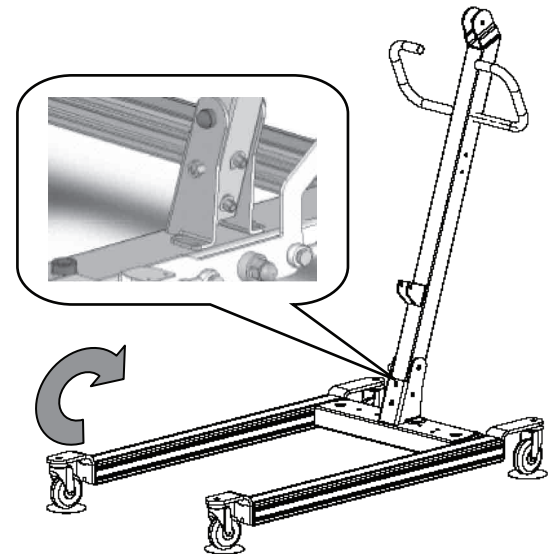

4. Reinstall the bolts in the holes at bottom of mast. Tighten the nuts.

5. Attach boom to top of mast.

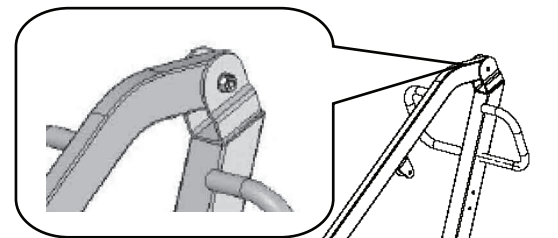

6. Reinstall the bolts in the holes at bottom of mast. Tighten the nuts.

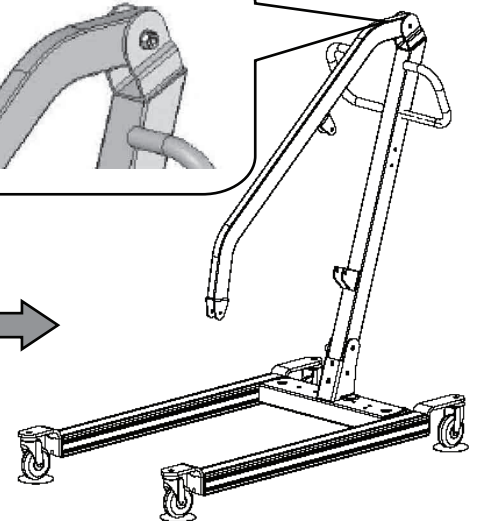
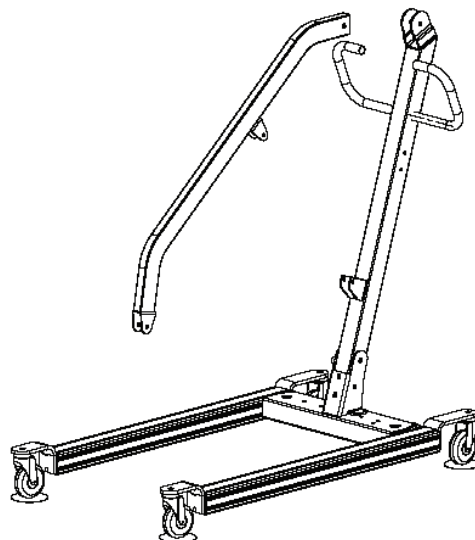

7. Attach the control box hanging bracket to the mast. Tighten the nuts.
8. Place the control box in the bracket.

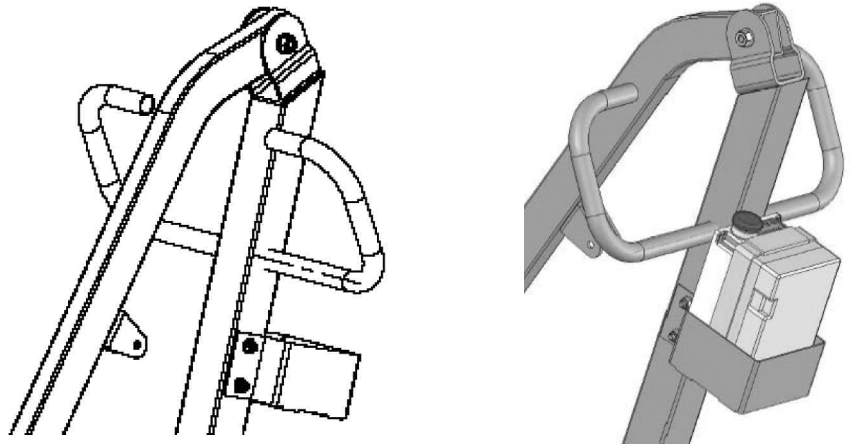

9. Attach the actuator bottom to the mast bracket and insert retainer pin. Insert retaining ring through retainer pin hole to secure actuator base to mast bracket.

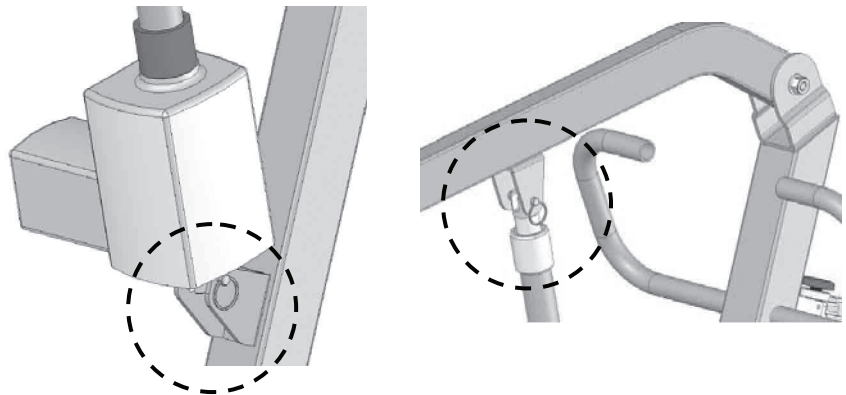

10. Attach the actuator top to the boom bracket and insert retainer pin. Insert retaining ring through retainer pin hole to secure actuator top to boom bracket.

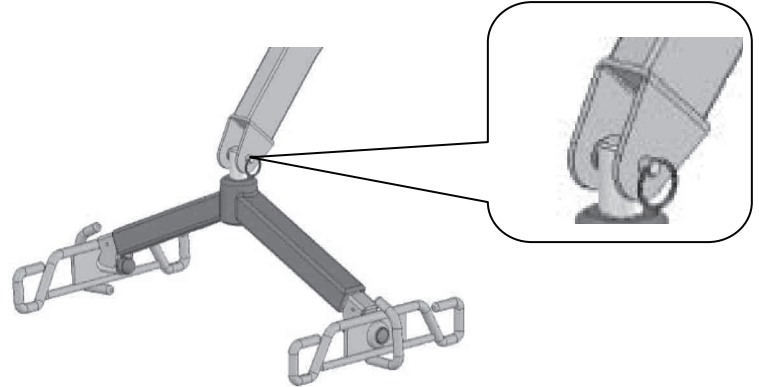

11. Attach the spreader bar bracket to the boom and insert retainer pin. Insert Retaining ring through retainer pin to secure spreader bar to boom.

12. Insert the actuator plug into the control box.
13. Insert the pendant plug into the control box.

Info: Before using the lift, charge the batteries for ten to twelve hours (see instructions on following page).

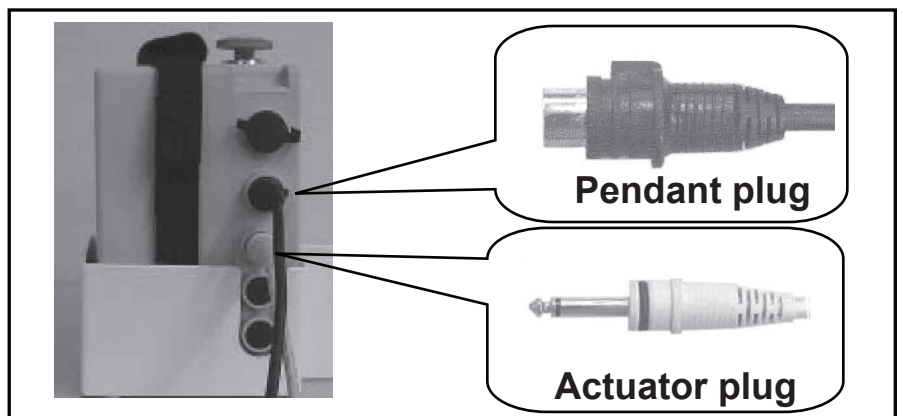

CHARGING THE BATTERIES

Charge the batteries after assembly.

1. Ensure the battery box power switch is ON (i.e., the red button is up).
2. Insert the charger plug into the battery box charging socket (the top slot).
3. Insert the other charger plug into the power supply.
4. All LED indicator lights should be ON during charging.
5. When one green LED indicator light illuminates, the batteries require approximately two to three hours to be fully charged.
6. When only the red LED indicator light illuminates, the batteries require approximately seven to nine hours to be fully charged.

▲ NOTICE: Do not charge the batteries for more than twelve hours.

7. Unplug the charger FIRST before using the lift.

Info: The lift will not operate while the batteries are charging.

The lift will not operate while the red reset button is down.

8. Replace the batteries when frequent charging is required.

Important Charging Information

Push lift to an appropriate location and charge the batteries with the charger provided.

▲ NOTICE: Avoid unplugging the hand control and motor from the control box. Frequent plugging and unplugging of the hand control and motor to and from the control box may damage the control box.

CHECKING BATTERY CAPACITY

Info: To check remaining battery capacity, press the battery indicator (blue circle with battery symbol) while the lift is not in motion. Remaining battery capacity is indicated by LED indicator lights and explained in the following table.

Red	Amber	Green	Green	Green	Status
ON	ON	ON	ON	ON	Fully charged
ON	ON	ON	OFF	OFF	Needs charge
ON	ON/OFF	OFF	OFF	OFF	Charge immediately—DO NOT use lift
ON	OFF	OFF	OFF	OFF	Bad batteries or bad connection

ALARM BUZZERS

The control box has an alarm buzzer that provides information on the status of the batteries and the lift. To stop the buzzer, push down the RED RESET button or press the battery indicator.

Buzzer type	Status	Note
2 beeps per second	Low battery (red/amber lights illuminate)	Charge batteries immediately
3 beeps per second	Low battery (red light illuminates)	Charge batteries immediately
6 beeps per second	Very low battery (no lights illuminate)	Charge batteries immediately
3 beeps every other second	Bad battery (no lights illuminate)	Replace batteries immediately
3 long beeps	Overloaded. Batteries are charged but lift does not lift	Maximum load capacity exceeded

6 OPERATING INSTRUCTIONS

- ⚠ WARNING: During lifting and lowering, whenever possible, always keep the base legs of the lift in the widest position.**
- ⚠ WARNING: Use only Lumex slings specially designed for the LF1090 Bariatric Patient Lift.**
- ⚠ WARNING: Do not put anything (e.g. cushion, pad, etc.) between the user and the sling. This may cause user to slide out of the sling and could cause injury.**
- ⚠ WARNING: GF Health Products, Inc. strongly recommends that two caregivers take part in the lifting process.**

Info: Instructional videos that review the application of several sling styles and lifting scenarios are available at www.grahamfield.com.

Info: While transferring a patient, the patient lift legs can be in either open or closed position.

Preparation before lifting

1. Turn on the power by turning the RED RESET BUTTON clockwise.
2. Press the hand pendant UP or DOWN button once.
3. After the battery indicator lights de-illuminate, push the hand pendant UP button and DOWN button to ensure the lift is operating correctly.
4. Position the lift base around or under the patient.
5. Widen the base.

LIFTING THE PATIENT

- ⚠ WARNING: Do not attempt to transfer a patient without prior approval of the patient's healthcare professional and without having read the instructions and practiced using the patient lift.**
- ⚠ WARNING: Use special care for those patients who cannot cooperate while being lifted.**
- ⚠ WARNING: Ensure all bolts, hooks, and loops are securely fastened.**
- ⚠ WARNING: Use only Lumex slings with the Lumex LF1090 Bariatric Patient Lift.**
- ⚠ WARNING: DO NOT use torn, cut, frayed or broken slings as injury could result.**
- ⚠ WARNING: Ensure the floor area is clear of any obstacle that could cause a caster to stop and possibly tip the patient lift.**

Lifting the patient from a bed

1. Position patient face-up in center of bed. Roll patient onto their side facing away from you.
 2. Fold sling lengthwise, outside out, and place it halfway under patient with lower edge just beneath knees and sling handle on the outside, facing away from patient. If the sling has a head support, ensure that it supports the patient's neck and head.
 3. Roll patient onto their side facing you. Pull sling out beneath patient inside up, smooth it, and center patient on sling.
 4. Pull the leg loops forward and under the thighs. Cross the loops, one through the other.
 5. Roll the patient lift under the bed, locating the spreader bar over the patient. Be careful not to lower the spreader bar onto the patient. Center the spreader bar over the patient before lifting.
- ⚠ **WARNING: Do not lock or block the patient lift casters when lifting. The casters must be free to roll so that the patient lift can stabilize as the patient is lifted from the bed.**
- ⚠ **WARNING: To ensure stability while lifting or lowering a patient, the patient lift legs should be in the maximum open position.**
6. Hook the sling loops onto the spreader bar.
 7. If the patient is in a hospital bed, raise the bed's head section to elevate the patient.
 8. Use the hand pendant to carefully and slowly raise the patient. If possible, lower the bed. Reposition the patient as needed, using the handle on the back of the sling, to ensure a safe and comfortable sitting position as the patient is raised.
 9. Raise the patient until the buttocks are just above the mattress. Lift the patient's legs and turn the patient to face the lifting column. Move the patient lift away from the bed. Ensure that the patient's arms and legs clear the patient lift, bed, or any other obstacles.

Lowering the patient onto a bed

1. Raise the patient lift until the patient's buttocks are above the surface of the bed. Ensure that there are no obstacles underneath or around the bed. Move the patient lift under the bed. Ensure the patient does not hit any portion of the bed and that the patient's legs have cleared the bed.
2. Center the patient over the bed, and rotate the patient to face the foot section of the bed. Use the hand pendant to SLOWLY lower the patient onto the bed. Support the patient's head, if necessary, while being lowered. Remove the sling by reversing the procedures used when lifting patient from bed.

Lifting the patient from the floor

1. Position the patient lift behind the patient, placing a pillow over the base to protect and support the patient's head and neck. Place the patient's head carefully on the pillow. Position the patient lift with the spreader bar centered over the patient.
2. Lower the spreader bar. Attach the sling to the spreader bar hooks.
3. Lift the patient up above the floor. Position the patient in the sling by pulling the handle on the back of the sling.
4. Turn the patient to face the lifting column. Remove pillow from base and place the patient's feet on the base, straddling the column for extra stability.

Lowering the patient to the floor

1. Place a pillow on the base to protect the patient's head and neck (this is unnecessary when using a sling with a head support).
2. Reverse the above procedures to lower.

Transferring the patient from a chair to a wheelchair or commode chair

⚠ WARNING: GF Health Products, Inc. recommends that two attendants be used when transferring a patient to and from a wheelchair.

1. Fold the sling.
2. While maintaining support, gently lean the patient forward. Place the folded sling behind the patient's back and push it down until it touches the seat of the chair.
3. Use the loops to pull the leg sections of the sling forward and beneath the patient's thighs. Then cross the loops, one through the other.
4. Move the patient lift around to the front of the chair.
5. Hook all sling loops onto the spreader bar.
6. Carefully raise the patient.
7. The second attendant should now move the wheelchair into position.
8. Engage the wheelchair wheel locks to prevent movement.

⚠ WARNING: Before transfer, ensure wheelchair wheel locks are in locked position. Wheelchair wheel locks must be in LOCKED POSITION before lowering the patient into the wheelchair, or unexpected wheelchair movement could result, which may result in serious injury to both the patient and the attendants.

9. Position the patient over the wheelchair with their back against the back of the wheelchair.
10. SLOWLY lower the patient into the wheelchair.
11. With one attendant behind the wheelchair and the other operating the lift, the attendant behind the chair should pull back on the handle or sides of the sling to place the patient into the back of the chair. This will maintain a good center of balance and prevent the chair from tipping forward.

Removing the sling

Gently pull the leg sections to the side, out from under the patient's thighs. Standing by the patient's side, lean the patient forward while supporting the patient with one hand. Pull the sling up from behind the patient's back and position the patient in the chair.

⚠ WARNING: DO NOT pull sharply on the sling. Pulling sharply on the sling may cause the patient to fall forward, resulting in personal injury. Always support the patient by keeping one arm around the patient's shoulders when placing or removing the sling.

Info: If possible, the patient should be encouraged to take an active part in removing the sling. The patient can lean forward, lift their thighs, and help in removing the leg sections.

Transferring the patient from a bed to a wheelchair or commode chair

1. For smooth, easy lifting, have the wheelchair or commode chair in ready position with wheel locks in locked position.
2. With patient face-up in center of bed, roll patient onto their side away from attendant.
3. Place sling, folded lengthwise, halfway under patient with lower edge just beneath knees.
4. Roll patient to side toward attendant, pull sling to smooth it, and center patient on sling.
5. Pull the leg loops forward and under the thighs.
6. Cross the loops, one through the other.
7. With base of lift under bed, Use the hand pendant to carefully lower spreader bar.
8. Attach sling to spreader bar.
9. Use the hand pendant to slowly lift patient, maintaining patient's position facing attendant, until patient's feet swing easily off the bed.
10. Position patient above wheelchair or commode chair. Lock lift brakes.

⚠ WARNING: Before transfer, ensure wheelchair or commode chair wheel locks are in locked position. Wheelchair wheel locks must be in LOCKED POSITION before lowering the patient into the wheelchair, or unexpected wheelchair movement could result, which may result in serious injury to both the patient and the attendants.

11. Use the hand pendant to SLOWLY lower patient. During descent, assist patient in attaining correct sitting posture.
12. When patient is seated, push down on boom to slacken sling loops. Patient can remain seated on sling.
13. For commode chair use, adjust clothing before moving lift to straddle commode chair. Keep sling loops taut and ensure that patient is in a comfortable position.

EMERGENCY RELEASE

In case of lift failure while using the Lumex LF1090 Bariatric Patient Lift, follow the procedures below to safely lower the user. The Emergency Lowering Device is located at the bottom of the actuator shaft. It is intended for use if the actuator fails to operate while a patient is suspended.

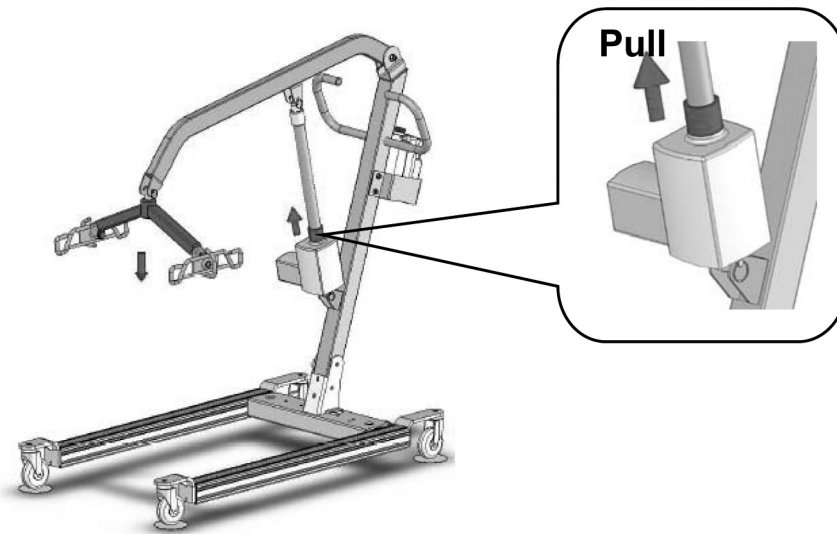

The quick release is available with a manual activation where a finger grip is mounted on the actuator. When pulling the finger grip the declutching is activated. Pull up the red emergency tab approximately one half inch using normal force. The actuator will then lower itself safely down. The lowering device will not lower unless weight is being applied.

Contact your dealer immediately if standard troubleshooting techniques do not correct the failure. Do not attempt to lift patients until all failure issues have been safely resolved.

Info: The emergency lowering device is intended for use during lift failure. This device will allow lowering of patients only. Please contact your authorized Graham-Field distributor immediately in case of failure.

7 CARE AND MAINTENANCE

Proper care and maintenance are essential to keeping your Lumex LF1090 Bariatric Patient Lift in a safe operating condition. In addition to inspecting the unit before each use, periodic maintenance checks should be done. We further recommend that this unit be serviced at least once annually by an authorized Graham-Field distributor.

- ⚠ WARNING: It is extremely important that the patient lift be inspected before each use. Ensure that all hardware and accessories are secure and that the actuator is functioning properly. Failure to do so could result in patient / attendant injury or damage to your patient lift. Torn, cut, frayed or broken slings can fail, resulting in serious injury. Only use slings in good condition. Inspect before each use. Destroy and discard old worn and unusable slings.**
- ⚠ WARNING: Service and repair of the LF1090 Bariatric Patient Lift should be performed only by an authorized Graham-Field distributor. Graham-Field is not responsible for any consequence resulting from any unauthorized service or repair.**
- ⚠ WARNING: Unauthorized modification of the patient lift or the use of non-Lumex replacement parts may change the structure of the lift and could create a hazardous condition, which may result in serious injury and will void the warranty.**
- ⚠ WARNING: The electronics and actuator contain no serviceable components. If service is required, the unit must be returned to the factory for repair. DO NOT attempt to open the electronics or actuator or obtain local service; this will void the warranty and may result in damage to the unit. Consult your authorized Graham-Field distributor for further information.**

When you believe a component or part is not functioning properly, immediately contact your authorized Graham-Field distributor, as a potentially hazardous condition could exist.

BEFORE EACH USE

Before each use of the patient lift, ensure that:

- All nuts and bolts are tight
- The base can be easily widened
- All lift parts are in place
- All casters turn freely
- Caster brakes can be engaged
- All necessary items (i.e. slings, wheelchairs, etc.) are accessible and ready for use
- Check battery capacity

AT LEAST ONCE A MONTH

The lift should be thoroughly inspected by a person qualified to recognize any signs of wear, and looseness of bolts or parts. Replace any worn parts immediately.

LUBRICATION

When the lift is serviced, and every month thereafter, place a drop of oil on the following points:

- Top of mast
- Spreader hinge
- Caster axles

CLEANING

Regular cleaning is recommended every three months; clean the lift more often as needed. A soft cloth, dampened with water and a mild NON-ABRASIVE detergent (household cleaner, soapy water, or hospital grade disinfectant) is all that is needed to clean your patient lift. Automobile wax or furniture polish will help maintain the finish over a long period of time.

▲ **NOTICE: DO NOT wash patient lift under water pressure or steam clean.**

CARE OF SLINGS

Lumex slings are washable at 150° F and autoclavable at 185° F for 30 minutes. The head support's plastic insert should be removed before washing. The slings can be air dried or dried by using a dryer on LOW heat.

▲ **NOTICE: DO NOT bleach slings!**

MAINTENANCE SCHEDULE

Info: Only qualified persons should service and repair your Lumex LF1090 Bariatric Patient Lift. Regular maintenance of your patient lift is necessary to ensure continuing proper and safe operation. Read and observe the following recommended maintenance schedule:

Item	Inspect	Inspect / adjust	
	initially	monthly	every 3 months
Boom & spreader bar			
Check connections between 1) boom and spreader bar and 2) boom and mast for improper connection, looseness, or wear	X	X	
Inspect boom for bending or deflection	X	X	
Mast			
Inspect mast for bending or deflection	X	X	
Inspect steering bar for damage or loose hardware	X	X	
Base and foot pedal			
Ensure all hardware is tight	X	X	
Ensure casters and axle bolts are tight	X	X	
Inspect rubber parts of casters for deflection	X		X
Apply grease to caster ball bearings if needed			X
Actuator and control box			
Ensure control box is firmly affixed to the mast	X	X	
Ensure pins that connect actuator to boom and mast are firmly affixed	X	X	
Ensure cable that connects actuator and control box is firmly affixed	X	X	
Ensure battery indicator has at least 2 green LEDs illuminated before use	X	X	
Sling and sling hardware			
Check sling for wear; discard if worn	X	X	
Ensure sling hardware is in good condition before each use	X	X	

8 TROUBLESHOOTING

The following list of encountered problems and their solutions will assist you in determining what may be causing your Lumex lift not to function as designed. If you have a problem occurring which is not listed below, please contact your distributor or GF Health Products, Inc. Technical Support for help. Do not attempt to repair components or parts on your lift, as this may invalidate your warranty or cause further problems that may result in patient injury. Stop using your lift immediately if it is not functioning correctly or any warning beeps are heard.

SYMPTOM	POSSIBLE CAUSE & SOLUTION
I need to recharge my batteries often or they fail to hold a charge when I charge them	Replace the two internal batteries as they are at the end of their life cycle
	Batteries should be changed every 18-24 months depending on usage
When I plug my charger into the control box I see no lights on the battery indicator	Check to make sure the red reset button is in the up position
	Check to make sure the charger is firmly in the control box and plugged into a wall socket
	Replace the charger as it is at the end of its life cycle
	If the charger is transmitting current, then you need to replace the control box PCB
My actuator makes a clicking sound when I attempt to use my lift	Check to make sure the actuator plug is pushed into the control box so the O-ring is not visible
	The actuator needs to be replaced as it is at the end of its life cycle
	The control box PCB may be malfunctioning
The actuator will either go up or down but not both	Replace the hand control as it is at the end of its life cycle
	The control box PCB may be malfunctioning
There is a grinding sound inside the actuator when lifting	Replace the actuator as the internal gears are stripped
The actuator stops and starts while lifting or lowering	Replace the batteries as they are at the end of their life cycle
My lift will not operate even though it shows the batteries are charged	Disconnect the charger from the control box as the lift will not work when the charger is attached
	Check to make sure the hand control is properly inserted to control box
	Check to make sure the actuator is properly connected to the control box
	The hand control needs to be replaced as it is at the end of its life cycle
My lift will not operate and battery indicator has no lights illuminated	Check to make sure the red re-set button is in the up position
	The internal batteries may not be connected together properly with the connection wires
	Batteries will no longer hold a charge and must be replaced
	The control box PCB is damaged and must be replaced
When lifting I hear 3 long beeps from the control box	You are attempting to lift someone heavier than the safe working load
	Stop the lift and lower safely to bed or chair immediately
When lifting I hear short beeping sounds from the control box	Charge the batteries
	Replace the batteries if they fail to hold a charge

⚠ WARNING: If you experience a problem with your lift and are unable to service it yourself, contact your Graham-Field provider.

9 SPECIFICATIONS *

Info: All dimensions are given in inches unless otherwise specified.

Base width	Open: 43"
	Closed: 26"
Base height clearance	4 7/8"
Base length	50"
Lifting height range Info: As measured from sling hooks.	Minimum: 27"
	Maximum: 71"
	Range: 35"
Mast height	50"
Weight capacity	600 lb (272 kg)
Caster size	3" diameter, both locking and non-locking
Lifting mechanism	24 DC actuator
Battery charger	AC 110V / 220V to DC 24V 1 amp

** Specifications are subject to change without notice.*

10 LIMITED WARRANTY

GF Health Products Inc. (“Graham-Field”) warrants this product to be free from manufacturing defects in material and workmanship for its period of warranty that is in accordance with industry standards. This warranty is extended only to the original purchaser/consumer or dealer/non-consumer of this new product and to no other purchaser or transferee.

GF Health Products, Inc. warrants the Lumex LF1090 Bariatric Patient Lift and its components to be free from defects in workmanship and materials as listed below:

Lift frame and spreader bar:.....	3 years
Actuator:	2 years
Parts, including casters, control box, PCB, pendant, charger: ...	2 years
Batteries:	1 year
DSC200 scale (sold separately):.....	2 years

The Warranty period for the consumer commences on the first date a product is delivered to consumer by seller/dealer. If the product is rented or leased, the warranty period commences on the invoice date from *GF Health Products, Inc.* A copy of the invoice showing date of purchase must be provided when submitting warranty claims. When proof of purchase date is not provided, warranty coverage shall commence upon *GF Health Products, Inc.*'s invoice date to the dealer/purchaser.

If within the warranty period, the product or component part is proven to *GF Health Products, Inc.*'s satisfaction to be defective, *GF Health Products, Inc.* shall provide, at its option, one of the following: (1) repair or replacement of any defective or nonconforming part or product or (2) a credit and/or refund of the original selling price. GF HEALTH PRODUCTS, INC.'S SOLE OBLIGATION AND YOUR EXCLUSIVE REMEDY UNDER THIS WARRANTY SHALL BE LIMITED TO SUCH REPAIR, REPLACEMENT, CREDIT AND/OR REFUND. This warranty does not include any labor charges incurred in replacement part(s) installation or any associated freight or shipping charges to the manufacturer.

For warranty service, please contact the authorized distributor from whom you acquired your *GF Health Products, Inc.* product. Upon receiving notice of an alleged defect in a product, *GF Health Products, Inc.* will issue a return authorization. The defective product or part(s) must then be returned, at the purchaser's cost, for warranty inspection using the serial number as identification (or, if the product is not serialized, lot number and date code) within thirty (30) days of return authorization issue date. In the event you do not receive satisfactory warranty service, please contact *GF Health Products, Inc.* at the address on the following page. DO NOT return products to our factory without prior authorization.

LIMITATIONS AND EXCLUSIONS: The foregoing warranty shall not apply to serial numbered products if the serial number has been removed or defaced. Products subjected to negligence, abuse, misuse, improper operation, improper maintenance, improper cleaning, improper storage, or damages beyond *GF Health Products, Inc.*'s control are not covered by this warranty, and that evaluation shall be solely determined by *GF Health Products, Inc.* This warranty shall not apply to problems arising from normal wear and tear or failure to follow instructions. The warranty shall also not apply to products modified without *GF Health Products, Inc.*'s express written consent; nor shall it apply if parts not manufactured by *GF Health Products, Inc.*, or if parts not complying with original equipment specifications are added to *GF Health Products, Inc.* products, or if the product or part is serviced by an entity not authorized by *GF Health Products, Inc.*

THE FOREGOING WARRANTY IS EXCLUSIVE AND IN LIEU OF ALL OTHER EXPRESS WARRANTIES AND IMPLIED WARRANTIES, INCLUDING BUT NOT LIMITED TO THE IMPLIED WARRANTIES OF MERCHANTABILITY AND FITNESS FOR A PARTICULAR PURPOSE, AND SHALL NOT EXTEND BEYOND THE DURATION OF THE EXPRESS WARRANTY PROVIDED HEREIN, AND THE REMEDY FOR VIOLATIONS OF ANY IMPLIED WARRANTY SHALL BE LIMITED TO THE REPAIR, REPLACEMENT, CREDIT AND/OR REFUND OF THE DEFECTIVE PRODUCT OR PART PURSUANT TO THE TERMS CONTAINED HEREIN. GF HEALTH PRODUCTS, INC. SHALL NOT BE LIABLE FOR ANY CONSEQUENTIAL OR INCIDENTAL DAMAGES WHATSOEVER.

This warranty gives you specific legal rights and you may also have other legal rights which vary from state to state (province to province). Some states (provinces) do not allow the exclusion or limitation of incidental or consequential damage, or limitation on how long an implied warranty lasts, so the above exclusion and limitations may not apply to you.

The warranties contained herein contain all the representations and warranties with respect to the subject matter of this document, and supersede all prior negotiations, agreements and understandings with respect thereto. The recipient of this document hereby acknowledges and represents that it has not relied on any representation, assertion, guarantee, warranty, collateral contract or other assurance, except those set out in this document.

GF Health Products, Inc. (“Graham-Field”)
2935 Northeast Parkway
Atlanta, GA 30360
Tel 770-368-4700
Fax 770-368-2386

11 INDEX

A

Assembly instructions 8

B

Before each use 17

C

Care and maintenance 16

Care of slings 18

CAUTION statement, significance 4

Cleaning 18

F

Features 6

H

Handling Procedures 7

I

Info statement, significance 4

Inspection 7

Intended use 3

Introduction 3

L

Lifting the patient 11

Lifting the patient from a bed 12

Lifting the patient from the floor 12

Lowering the patient onto a bed 12

Lowering the patient to the floor 13

Lubrication 17

M

Maintenance schedule 18

N

NOTICE statement, significance 4

O

Operating Instructions 11

R

Removing the sling 13

S

Safety precautions 4

Safety statements, significance of 4

Shipping and transportation instructions 7

Specifications 20

Storage 7

T

Transferring the patient from a bed to a wheelchair or commode chair 14

Transferring the patient from a chair to a wheelchair or commode chair 13

Troubleshooting 19

U

Unpacking 7

V

Videos, instructional, at www.grahamfield.com 11

W

Warnings 4

WARNING statement, significance 4

Warranty, limited 21

Weight capacity 4

USA Company Headquarters:

**GF Health Products, Inc.
2935 Northeast Parkway
Atlanta, Georgia 30360 USA**

tel: 770-368-4700

fax: 770-368-2368



GRAHAM-FIELD
www.grahamfield.com