

GUARDIAN[®]

Guardian[®] Easytrack System 2-Post Assembly

Model 92000

Installation & Instruction Manual



TABLE OF CONTENTS

Introduction 2

Important Safeguards 3

Requirements 4

Before You Begin 5

Kit Contents & Part Numbers 6

Assembly of 2-Post System 6

Disassembly of 2-Post System 9

2-Post Specifications 10

Maintenance 11

Troubleshooting 13

Easytrack Products & Accessories 14

Warranty 15

⚠ WARNING

This manual contains important safety and maintenance instructions. Please read it carefully before using your Easytrack System and refer to it as often as needed for safe and efficient use.

If you have questions regarding the safe use and/or assembly, maintenance or specifications of your Easytrack System, you should call Customer Service at 800-333-4000, 303-218-4600 or from Canada at 800-263-3390.

For service and repair, remember your authorized Sunrise supplier is able to provide the assistance you need.

Save this manual for future reference.

SUNRISE LISTENS

Thank you for choosing a Guardian Easytrack System. We want to hear your questions or comments about this manual, the safety and reliability of your Easytrack System and the service you receive from your Sunrise Medical Supplier. Please feel free to write or call us at the address and telephone number below:

Sunrise Medical
 Customer Service Department
 7477 East Dry Creek Parkway
 Longmont, Colorado 80503
 (303) 218-4600 or (800) 333-4000

FOR ANSWERS TO YOUR QUESTIONS

Your authorized supplier knows your Easytrack System best and can answer most of your questions about its safety, use and maintenance. For future reference, fill in the following:

Supplier: _____

Address: _____

Telephone: _____

Serial #: _____

Date Purchased: _____

IMPORTANT SAFEGUARDS

⚠ WARNING

Do not operate this equipment without first reading and understanding this manual.

⚠ WARNING

Should you be unable to understand the warnings, cautions and instructions, contact our technical support or your local dealer before attempting to use this equipment— otherwise injury or damage may result.

Important information is highlighted by these terms:

⚠ WARNING– Notices as used in the manual apply to hazards or unsafe practices which could result in serious bodily harm.

CAUTION– Notices as used in this manual apply to hazards or unsafe practices, which could result in minor personal injury or property damage.

NOTES– Highlight procedures and contain information which assist the operator in understanding the information contained in this manual.

NOTE– The information contained in this document is subject to change without notice.

SAVE THESE INSTRUCTIONS AND KEEP WITH EASYTRACK AT ALL TIMES.

⚠ WARNING

The Easytrack System and its accessories are intended to be used as an assistive device for transferring a person between the posts. The Easytrack system is only to be used with the Guardian Voyager Portable lift.

⚠ WARNING

USE ONLY AS INTENDED - This product may cause serious injury if not installed and operated according to the instruction manual.

Failure to observe warnings listed below could result in serious injury.

Before You Install the Easytrack

⚠ WARNING

- Carefully inspect product upon arrival. If any pieces are missing or appear damaged, do not install. Contact your local supplier for further instructions.
- If you are unsure of the strength or stability of your floor and/or ceiling, do not install the Easytrack System - consult you local supplier.
- Easytrack can not be used with any type of suspended ceiling, including suspended drywall, acoustic tile, etc.
- Installation on a plaster ceiling may cause cracking. Sunrise Medical cannot be held responsible for damage.
- Do not install on a ceiling with water damage.
- Do not over-tighten ceiling plate as this may cause ceiling to crack.
- If flooring is not according to local building code standards, flooring may be damaged.
- Do not install on a sloped floor.
- Do not drop product; may cause breakage.
- Do not completely submerge in water.
- Do not attempt to over-extend the rail past the locking point.
- Do not install product if neoprene on top or bottom plate appears to be damaged or absent.

When the Easytrack is in Use

⚠ WARNING

- Do not hit posts - this might cause unit to become unstable. If posts are hit, reassemble Easytrack System to ensure the posts are straight.
- If you use a power wheel chair, use extreme care. Hitting posts may cause unit to become unstable. If posts are hit, reinstall the Easytrack System to ensure the posts are straight.
- Do not lean against posts.
- Do not use the Easytrack System as a swing.
- Refrain from swinging user sideways of rail.

REQUIREMENTS

⚠ WARNING

Failure to meet requirements listed below could result in serious bodily harm.

Ceiling Requirements

- Install to a rigid ceiling (must have a framework above it).
- Must have a maximum of 24" (610mm) between the trusses in the ceiling.
- Ceiling must be made of wood or 1/2" (12.7mm) sheet rock or thicker.
- Ensure ceiling and floor are clear of any dust, grease, water or any foreign substance.

⚠ WARNING

A build-up of nicotine, grease or water on the ceiling will affect the integrity of the Easytrack System.

- Installing a post directly under a joist or truss is not required, but preferable.

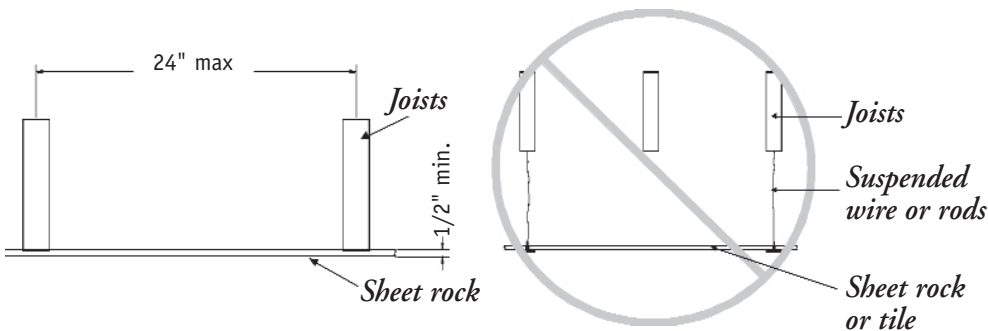

Floor Requirements

- Ensure flooring meets local building code standards. (Termites or water damage may affect the structure of the floor).
- Ensure floor is clear of any dust, grease, water or any foreign substance.
- Floor must not have a slope of more than 0.5°. See drawing below to determine the floor slope. Use a level or contact a contractor if unsure of floor slope.

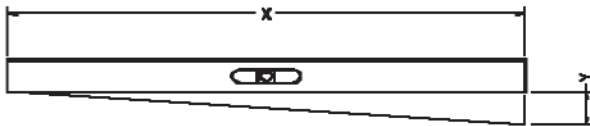

X	12" (300mm)	24" (600mm)	36" (900mm)	48" (1200mm)
Y	0.10" (2.6mm)	0.21" (5.2mm)	0.31" (7.9mm)	0.42" (10.5mm)

⚠ WARNING

- Ensure posts are straight using the level provided; failure to do so may cause injury.
- Every month a maintenance check should be done to ensure all posts are level. (See "Maintenance" section in this manual).
- Make sure the padded surface of the top plate and foot plate are kept clean and are intact.
- Protect the Easytrack System and its accessories during transport.

BEFORE YOU BEGIN

⚠ WARNING

Read "Requirements" and "Important Safeguards" before attempting to assemble the Easytrack System.

1. Survey the room where you plan to install the Easytrack System. Make sure the room meets all the specifications outlined in "Requirements".
2. Use the measurements below to determine the best place to put the Easytrack System:
 - a. Over a bed - approx. 36-40" (915-1020 mm) from the head of the bed (Figure 1).
 - b. Over a tub - approx. 16-18" (400-460 mm) from the end of the tub (Figure 1).
 - c. Allow 36" (1000 mm) of open area for transfer working space (Figure 2).
 - d. Transfers should only take place between the Easytrack System posts (Figure 3).
3. Though it is not a requirement to place the posts directly under a joist in the ceiling, it is preferable. It does not matter which direction the top plate is facing (Figures 4 & 5).

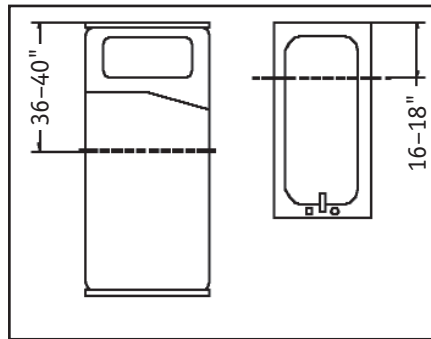

Figure 1

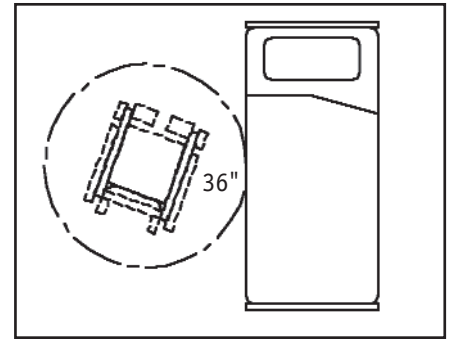

Figure 2

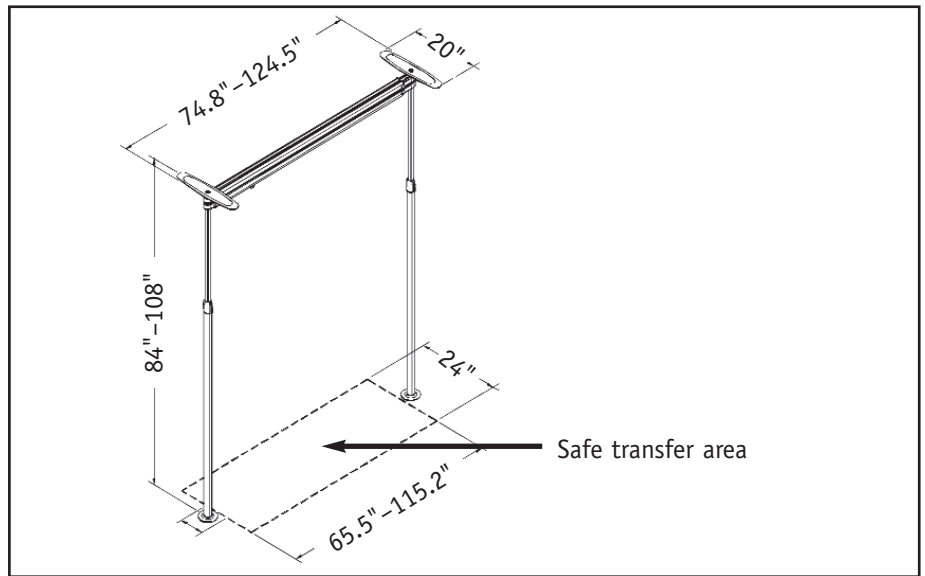

Figure 3

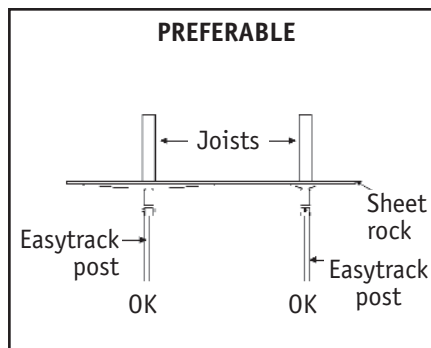

Figure 4

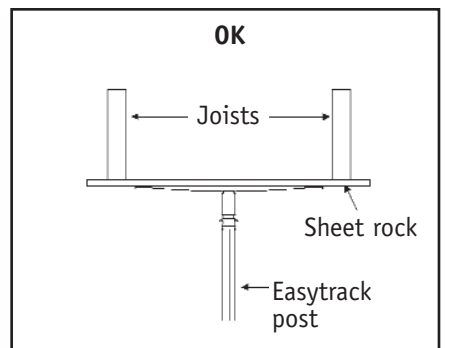

Figure 5

EASYTRACK 2-POST SYSTEM KIT CONTENTS & PART #'S (Figure 6)

Description	Part #	Qty
1 Extendable rail w/standard trolley	900-0750	1
2 Standard trolley	900-0650	1
3 Blue locking handle	N/A	2
4 Standard post	900-050	2
5 Blue plastic strips	900-0230	4
6 Round foot plate	900-0350	2
7 Clip-on level	900-0600	1
8 Top plate	900-0400	2
9 Round blue cap	900-0720	2
10 C-H protector	900-0780	2

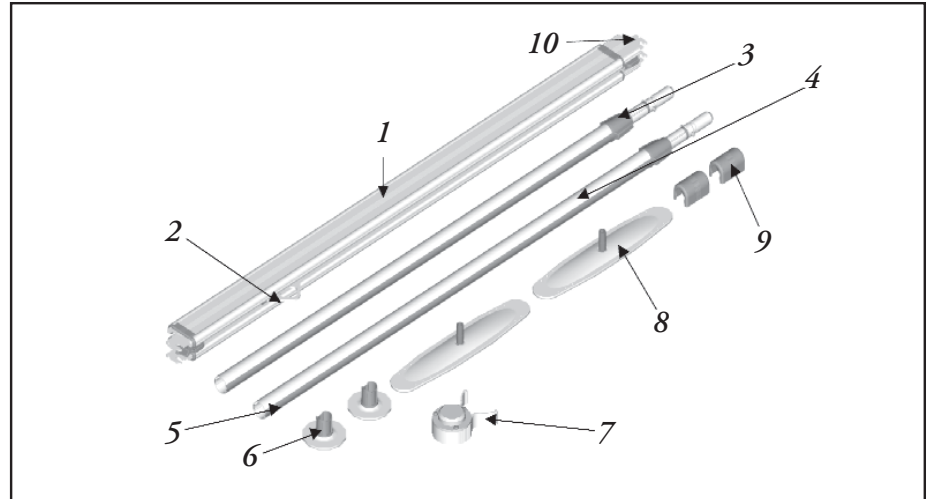

Figure 6

ASSEMBLY OF 2-POST SYSTEM

Tools Required:

- Step ladder
- Tape measure
- An assistant

1. Remove the round blue caps from the top of each post by pulling them away from the post (Figure 7).
2. Remove the blue plastic strips from each side of the posts. Take one end and pull gently (Figure 8).
3. Place one round foot plate on the floor where you want to place the first post of the Easytrack System.
4. Take one of the posts, one top plate, and the clip-on level out of the box. Turn the post upright. Place the clip-on level onto the post at approximately waist height (Figure 9).
5. Place the post onto the foot plate and press down to tighten. Pay attention to the shape of the post and foot plate before pressing the post down onto the foot plate.
6. Place the top plate into the top of the post, press firmly and evenly downward until the top plate "clicks" into place (Figure 10).
7. Extend the post quickly towards the ceiling by pulling the top portion upwards and holding the bottom portion. The post should be within 3" (76 mm) to touching the ceiling. If the top of the post is more than 3" (76 mm) from the ceiling:
 - a. Raise the top portion of the post slightly (Figure 11).
 - b. Press in metal pins on both sides of the post (Figure 12).

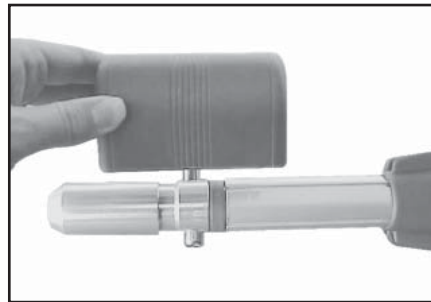

Figure 7

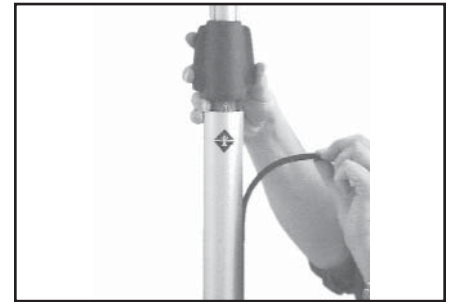

Figure 8



Figure 9

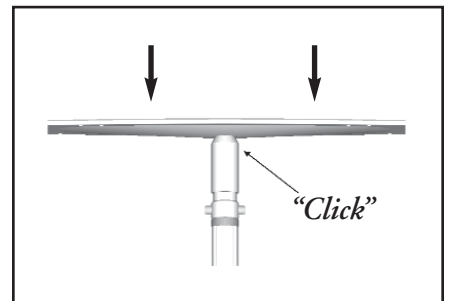

Figure 10



Figure 11

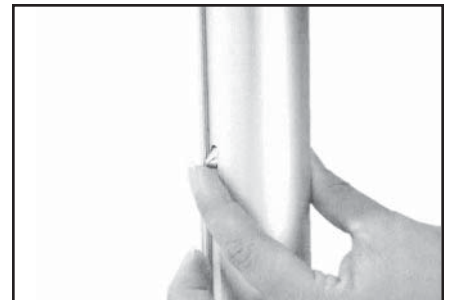

Figure 12

CAUTION– Metal pins cannot be pressed in when there is downward pressure on them. Pressure must be released to press in pin.

- c. Pull top portion of post up towards the ceiling.
 - d. Repeat until the top of the post is less than 3" (76 mm) from the ceiling.
8. Lift the blue locking handle out of the lower portion of the post. Using the blue piece as a handle, twist the post as follows (Figure 13):
- a. Turn the top portion counter-clockwise.
 - b. Hold the bottom portion firmly.
9. Before the Easytrack post tightens against the ceiling, check the clip-on level to make sure the bubble is in the center of the circle. Tilt the post until the bubble moves to the center of the circle (Figure 14).

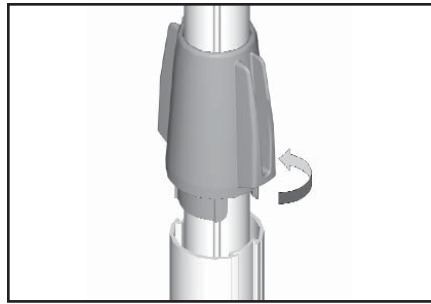

Figure 13

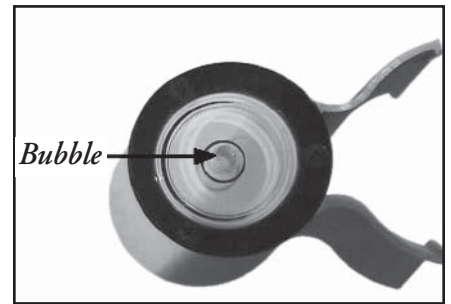

Figure 14

- ▲WARNING**
Make sure clip-on level is fully attached to the post. Failure to attach level properly could give an incorrect reading. Level should "click" into place.
10. Once the bubble is in the center of the clip-on level, continue to tighten ONLY until the red zone at the top of the post is no longer visible (Figure 15-A & B).

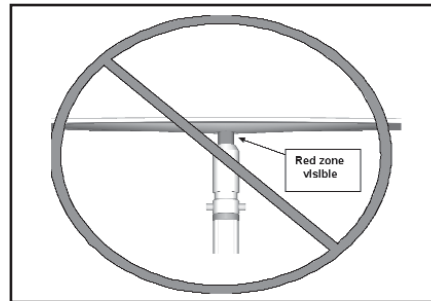

Figure 15-A

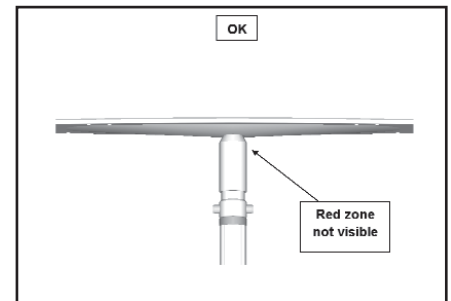

Figure 15-B

▲WARNING

Red zone must not be visible for the post to be safely secured.

▲WARNING

Do not over-tighten the post. Tighten only until red zone disappears. Over-tightening post may cause damage to the ceiling.

11. Remove the level from the post by sliding it up off the bottom portion of the post. Slide the blue locking handle down to fit into the bottom part of the post to lock the post in place (Figure 16).
12. Repeat steps 3-11 for second post.

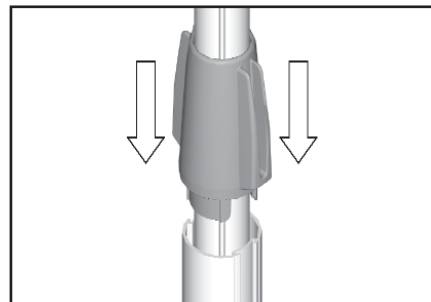

Figure 16

NOTE– Once the blue locking handle is pressed into the lower portion of the post, the post can be turned as a whole except for the top and foot plates. This will not lower the post. The post must turn to enable you to attach the rail.

NOTE– Make sure the second post is far enough away to allow the rail to attach– minimum distance between the post is 75"(1.9 m).

13. After you have both posts secured, place the end of the rail marked "Step 1" onto one post (Figure 17). If pins on top of post are not facing in direction desired, place rail onto pins and rotate post to desired direction.

NOTE– Tilt the rail upward (45°) to latch the rail onto the post (Figure 17).

14. Raise the rail slightly and extend the rail to the second post (Figure 18).

NOTE– Do not squeeze sides of rail together when attempting to extend or contract the rail. Squeezing the rail makes it more difficult to slide.

15. Latch the end of the rail marked "Step 2" onto the second post. The rail should "click" in place. Press up on the rail to make sure it is locked into place.

16. Place one blue end cap on each end of the rail (Figure 19).

17. Put the level in a safe place, as you may need it in the future.

18. Slide the blue plastic strips into the sides of the posts by pinching the strip together pressing it into the grooves. Start at the bottom of the post (Figure 20).

19. See Diagram 17 for photo of assembled 2-Post Easytrack System.

⚠ WARNING

BEFORE USING THE EASYTRACK SYSTEM GO THROUGH THE FOLLOWING CHECKLIST:

- ✓ Make sure the red zone on top of all posts is not visible.
- ✓ Make sure the posts are straight. (Did you use the clip-on level?)
- ✓ Make sure the rail is locked into place (see step 15) and that it looks level.
- ✓ Check your installation against Figure 21.
- ✓ Is the blue locking handle secured down into the lower portion on both posts?

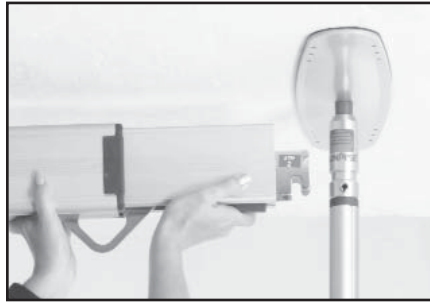

Figure 17



Figure 18

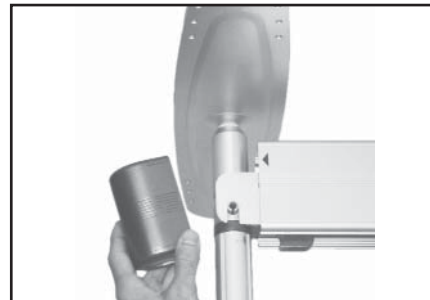

Figure 19



Figure 20



Figure 21

DISASSEMBLY OF 2-POST SYSTEM**⚠ WARNING**

Ensure no one is in the lift and remove the lift from the Easytrack before adjusting or disassembling the Easytrack System.

Tools Required:

- Step ladder
- An assistant

1. Remove plastic strips from the sides of the post. Take one end of the strip and pull outward gently (Figure 8).
2. Remove the round blue cap from the ends of the rail by pulling them away from the post (Figure 7).
3. Using a step ladder, reach under the section of the rail labeled "Step 2". Pull the blue tab away from the post slightly to release the lock on the rail (Figure 22).
4. Push end of rail to contract the rail and tilt the rail downward (45°). The other end of the rail should easily be released from the post (Figure 17).
5. Place the rail in a box or bag to protect it from dust and/or other damage.
6. To remove the post, slide the blue locking device up out of the bottom part of the post to unlock it.

NOTE– Do not squeeze sides of rail together when attempting to extend or contract the rail. Squeezing the rail makes it more difficult to slide.

7. Loosen the post by twisting as follows (Figure 23):
 - a. Turn top part of post to the left.
 - b. Hold bottom part of post firmly.
8. Once the post is loose enough to allow you to move it, slide the top portion of the post down:
 - a. Slide the blue locking device down into the bottom portion of the post.
 - b. Raise the top portion of the post slightly (Figure 4).
 - c. Press in metal pin on both sides of the post (Figure 12).
 - d. Push top portion of post downwards.
 - e. Repeat until the metal pins are no longer visible and the top of the post is only 6-8" (152-200mm) above the blue locking handle.

NOTE– Metal pins cannot be pressed in when there is downward pressure on them. Pressure must be released to press in pins.

9. Remove the top plate from the post by pressing up evenly.
10. Remove the post from the foot plate by stepping on both sides of the foot plate with your feet and pulling the post up.
11. Place all pieces into a box or bag to protect them from dust and/or damage.
12. Repeat steps 6-11 for the second post.

NOTE– Put the level with the rest of the Easytrack System for the next time you need to assemble it.

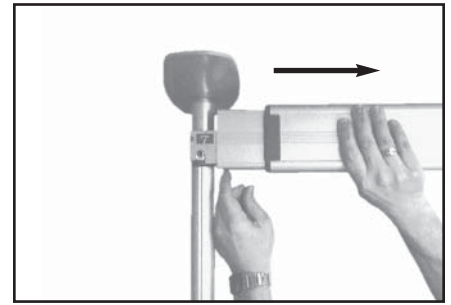

Figure 22

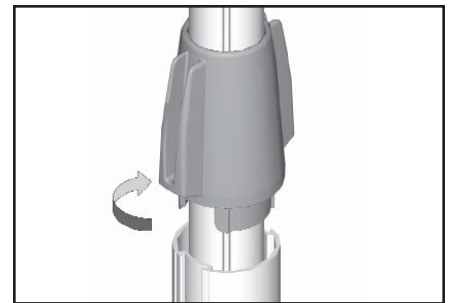
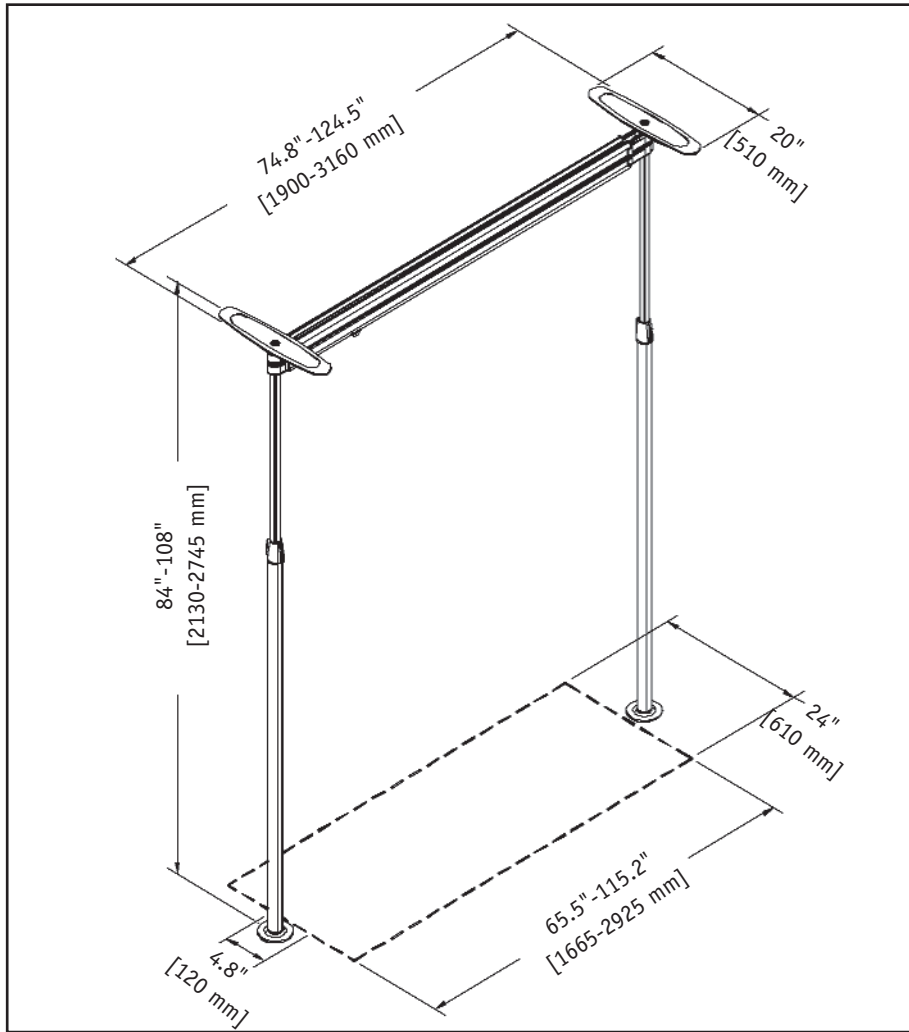

Figure 23

2-POST EASYTRACK SPECIFICATIONS



- Item Number.....92000
- Weight Capacity440 lbs. (200 kg)
- Length of Rail.....74" - 124.5"
(1900-3160mm)
- Length of Posts84" - 108"
(2130-2745mm)
- Material.....Anodized Aluminum
- Weight44lbs. (20kg)
- Ceiling Plate20" (510 mm)
- Floor Plate.....4.8" (120 mm)

MAINTENANCE**⚠ WARNING**

Maintenance must be performed only by qualified personnel.

⚠ WARNING

Failure to follow maintenance instructions below when indicated could result in injury or damage.

⚠ WARNING

Periodic inspection should be performed by a person who is suitably and properly qualified and well acquainted with the design, use and care of the Easytrack System.

Inspection should be carried out both routinely (at least as often as specified) and as necessary. All defects and damage that have lead to corrective actions should be noted, signed and dated by the inspector. Defects and resulting actions should be reported in writing to your supplier.

Upon receipt of your Easytrack System:

1. Make sure you received all components listed in Figure 6.
2. Inspect all parts for possible damage in transit.
3. Ensure all components are in working order.
4. Arrange for repair/replacement of any faulty parts.
5. Keep a log of any repair/replacement required.

Before each use of the Easytrack System:

1. Make sure posts are straight. If they do not appear straight, use level to check. If posts are not straight, remove rail (see Disassembly) and reinstall posts (see Assembly).
2. Ensure that the red zone on top of the post (under the top plate) is not visible.
3. Check that rail is secured in place. Press up on the rail to make sure that it is locked onto the post.
4. Check for any appearance of damage. If there is apparent damage, do not use the Easytrack System.

Every month perform the following steps:

1. Use level supplied to ensure all posts are straight.
2. Clean inside of rail with a damp cloth to ensure there is no dust or grease build-up inside of rail.
3. Make sure the red zone is not visible. If red zone is visible tighten posts according to assembly instructions.
4. Check to ensure you still have all your original parts. If any parts are missing they should be replaced BEFORE USING THE EASYTRACK AGAIN.
5. Check to make sure that the trolley in the rail moves freely. Trolley may need to be cleaned or replaced.
6. Check for the appearance of rust. If rust is starting to appear, simply scrub the piece clean.
7. Examine all joints and pieces for wear and fatigue. Replace any part that looks damaged or worn.
8. Document inspection and any repairs.

If equipment is moved on a regular basis, perform the following steps:

1. Make sure all components are accounted for.
2. Check "Requirements" and "Important Safeguards" before reinstalling the Easytrack System.
3. Make sure the padding on the foot and top plate is clear of any foreign substance and is not damaged. If neoprene (rubber) on either top or bottom plate appears damaged, the plate must be replaced.
4. Make sure the level is still working.
5. Look for signs of wear or breakage on all parts. Replace any parts that appear worn or damaged.

WARNING

Follow guidelines in your portable lift manual for maintenance and procedures on the lift.

TROUBLESHOOTING

PROBLEM	CORRECTION
<p>1. Trolley moves substantially on its own when the Easytrack System is fully assembled.</p>	<ol style="list-style-type: none"> 1. Are posts straight? Use level (see assembly instructions step 9 & 10). 2. Are the rails secured to the posts? Press up on the rail to make sure that the rail is latched onto the post. 3. Is the ceiling level? An uneven ceiling will make the rail uneven. See "Requirements" section in manual.
<p>2. Extendable rail comes completely apart during assembly.</p>	<ol style="list-style-type: none"> 1. Rail has been extended too quickly/forcefully. Rail was pulled past the locking device. 2. Check locking device inside rail (top of rail above the trolley) to make sure it is not damaged. Replace trolley if damaged. See "Easytrack Kit Contents and Part Numbers" section of manual. 3. Put rail back together at a slight angle and slide together. 4. Slowly extend rail out again to make sure locking device clicks into place. 5. Slowly compress rail again.
<p>3. Not able to push pin to assemble/disassemble post.</p>	<ol style="list-style-type: none"> 1. Is the post still tight against the ceiling? Release pressure on posts by unscrewing blue locking device. See Disassembly instructions step 7. 2. Are you lifting the upper portion of the post slightly to release pressure? Raise upper portion of post first and push the pin in. See Assembly instruction step 7 or Disassembly instructions step 8. 3. Is the blue locking handle up out of the lower portion of the post when turning the upper portion to the right? See Assembly instructions step 8.
<p>4. Not able to tighten post enough to hide red zone.</p>	<ol style="list-style-type: none"> 1. Have you extended the post enough? Unscrew using the blue locking handle (see Disassembly instruction step 7), slide post up one or more notches, then screw the upper portion of the post to tighten. See Assembly instructions steps 7-8. If the post has been "unscrewed" to the maximum and will not turn anymore, reverse direction to shorten the post several inches, then slide the post up another notch. See Assembly instruction steps 7-8. 2. Is the blue locking handle up out of the lower portion of the post when turning the upper portion to the right? See Assembly instructions step 8. 3. Are you holding the bottom portion of the post firm while twisting the upper portion of the post towards the right? See Assembly instructions step 8.
<p>5. Posts do not appear stable.</p>	<ol style="list-style-type: none"> 1. Is red zone still visible? See Assembly instructions step 10 and Troubleshooting problem #4. 2. Is neoprene (rubber) on either top plate or foot plate damaged or dirty? Clean both foot plate and ceiling plate with soap and warm water. Make sure they completely dry before reassembling post. 3. Replace foot plate(s) or top plate(s) if neoprene is damaged. 4. Is ceiling clean? Clean ceiling and/or floor. See "Requirements" section of manual.
<p>6. Trolley does not roll in rail smoothly.</p>	<ol style="list-style-type: none"> 1. Is rail clean? Clean rail with damp cloth. 2. Is trolley centered in rail? Re-center trolley. 3. Is the trolley damaged? Replace trolley. See "Easytrack Kit Contents & Part Numbers".

EASYTRACK PRODUCTS & ACCESSORIES

Description	Part #
Easytrack 3-Post System.....	93000
Easytrack 4-Post System.....	94000
Easytrack 2-Post with Tub Bracket	92001
Easytrack 3-Post with Tub Bracket	93001
Easytrack Portable Carry Bag.....	92341

WARRANTY

This warranty is extended only to the original purchaser/user of Sunrise products.

Sunrise Medical Inc. warrants its products to be free from defects in material under normal use and service and will, within the periods stated below, from the date of purchase. If within such warranty period any such product shall be proven to be defective, such product shall be repaired or replaced at Sunrise Medical's option. This warranty does not include any labor or shipping charges incurred in replacement part installation or repair of any such product. Sunrise Medical's sole obligation and your exclusive remedy under this warranty shall be limited to such repair and/or replacement.

Lifter including Hydraulics	1 year
Accessories on Lifter	1 year
Slings	1 year
Voyager Portable Batteries	3 months
Easytrack System	1 year

For warranty service, please contact the provider from whom you purchased the Sunrise Medical product. In the event that you do not receive satisfactory warranty service, please contact Sunrise Medical Customer Service at 1-800-333-4000.

Do not return products to our factory without prior authorization. Sunrise Medical will issue a Return Merchandise Authorization (RMA) Number. C.O.D. shipments will be refused; all shipments to Sunrise Medical must be prepaid. For this warranty to be valid, the purchaser must present its original proof of purchase at the moment of the claim. The defective unit, assembly or part must be returned to Sunrise Medical for inspection. The part or components repaired or replaced are guaranteed for the remaining period of the initial warranty.

Limitations and Exclusions:

The above warranty does not apply to serial numbered products if the serial number has been removed or defaced.

No warranty claim shall apply where the product or any other part thereof has been altered, varied, modified, or damaged either accidentally or through improper or negligent use and storage. Warranty does not apply to products modified without Sunrise Medical's express written consent, (including but not limited to products modified with unauthorized parts or attachments), products damaged by reason of repairs made to any component without the specific consent of Sunrise Medical, or to products damaged by circumstances beyond Sunrise Medical's control. Evaluation of warranty claim will be solely determined by Sunrise Medical. The warranty does not apply to problems arising from normal wear or failure to adhere to the instructions in this manual. Sunrise Medical slings are void of warranty if not laundered as per instructions on the sling label.

Sunrise Medical shall not be liable for damages, losses or inconveniences caused by a carrier.

This warranty replaces any other warranty expressed or implicit and constitutes Sunrise Medical's only obligation towards the purchaser. Sunrise Medical shall not be liable for any consequential or incidental damages whatsoever.



Distributed by:
Sunrise Medical

7477 East Dry Creek Parkway
Longmont, Colorado 80503
(800) 333-4000
In Canada (800) 263-3390
Printed in Canada

© 2001 Sunrise Medical 8.01
900-1600 Rev. A