

PLAN VIEW
PLATFORM SHOWN AT LOWER LEVEL (1)

NOTES:

THIS DRAWING IS GENERIC AND PROVIDED TO ILLUSTRATE LIFT-U'S RECOMMENDED VMW LIFT / MILLWORK INTERFACE.

THE DIMENSIONS AND DETAILS WILL VARY FOR EACH APPLICATION. THEREFORE, FOR EACH PROJECT APPLICATION REFER TO ITS CORRESPONDING LIFT CONFIGURATION DRAWING FOR GENERAL ARRANGEMENT LAYOUT AND LIFT ENVELOPE DIMENSIONS.

ALL MILLWORK FRAMING AND VENEERED PANEL FINISHES ENCASING THE LIFT ARE FURNISHED AND INSTALLED BY OTHERS.

THIS DRAWING ILLUSTRATES A LIFT PLATFORM AND OPERATING MECHANISM WITHIN THE PARAMETERS OF MILLWORK WALLS. THE LIFT PLATFORM REQUIRES 3/8" MINIMUM TO 3/4" MAXIMUM RUNNING CLEARANCE WITH ADJACENT MILLWORK FINISHED SURFACES. THE MILLWORK SHOWN IS FOR ILLUSTRATIVE REFERENCE ONLY. DIMENSIONAL EXTENTS OF THE MILLWORK IS THE RESPONSIBILITY OF OTHERS.

MILLWORK WALLS ARE SHOWN IN SHADED / TRANSPARENT MODE ON SHEET 1 OF 5 TO VIEW ENCASED LIFT ASSEMBLY.

POWER NOTE:
BUILDING POWER TO BE SUPPLIED AND ROUTED TO ELECTRICAL CONTROL PANEL BY OTHERS. FURNISH 115 VAC, 3 WIRE, 15 AMP, SINGLE PHASE SOURCE POWER.

- ADVISORY NOTES:**
1. THIS DRAWING IS SUBJECT TO CHANGE PENDING APPLICABLE STATE AND LOCAL CODES, AND CUSTOMER APPROVAL.
 2. CUSTOMER MUST PROVIDE APPLICABLE STATE AND LOCAL CODES TO LIFT-U PRIOR TO DESIGN.
 3. PRIOR TO INSTALLATION, THE CUSTOMER MAY BE REQUIRED TO OBTAIN A VAIRANCE FROM THE PRESIDING AUTHORITY FOR NON-COMPLIANT FEATURES.
 4. DRAWING MUST BE SIGNED BY CUSTOMER AND RETURNED TO LIFT-U PRIOR TO PRODUCTION RELEASE. CUSTOMER APPROVAL SIGNIFIES THAT ALL DIMENSIONS ARE CORRECT TO THEIR SPECIFICATIONS.
 5. SEE SHEET 5 OF 5 FOR LIFT SPECIFICATIONS.

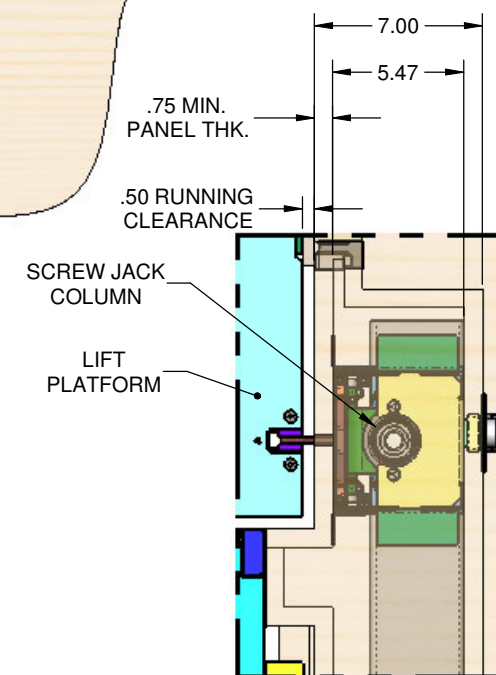

DETAIL D

REFERENCE ONLY

 LIFT-U P.O. BOX 398 ESCALON, CA. 95320 209-838-2400	THIS DOCUMENT IS AND CONTAINS CONFIDENTIAL TRADE SECRET INFORMATION OF THE COMPANY. NO PART OF IT MAY BE REPRODUCED, STORED IN A RETRIEVAL SYSTEM, OR TRANSMITTED IN ANY FORM OR BY ANY MEANS ELECTRONICALLY, PHOTOCOPYING, RECORDING OR OTHERWISE, WITHOUT THE PRIOR WRITTEN PERMISSION OF HOGAN MFG., INC. THIS DOCUMENT IS LOANED FOR THE LIMITED PURPOSES STATED HEREIN ONLY, AND REMAINS THE PROPERTY OF THE COMPANY.	
	A DIVISION OF HOGAN MFG., INC.	
TITLE LIFT CONFIGURATION, 7"-14" RISE		
DOCUMENT NO. 910-0091	SHEET NO. 1 OF 5	REVISION A

NOTES:

THIS DRAWING IS GENERIC AND PROVIDED TO ILLUSTRATE LIFT-U'S RECOMMENDED VMW LIFT / MILLWORK INTERFACE.

THE DIMENSIONS AND DETAILS WILL VARY FOR EACH APPLICATION. THEREFORE, FOR EACH PROJECT APPLICATION REFER TO ITS CORRESPONDING LIFT CONFIGURATION DRAWING FOR GENERAL ARRANGEMENT LAYOUT AND LIFT ENVELOPE DIMENSIONS.

ALL MILLWORK FRAMING AND VENEERED PANEL FINISHES ENCASING THE LIFT ARE FURNISHED AND INSTALLED BY OTHERS.

LIFT SCREW JACK COLUMNS TO BE ENCASED IN MILLWORK. MILLWORK IS SUPPLIED AND INSTALLED BY OTHERS. SIDES FACING THE PLATFORM TO BE COMPLETED AFTER THE LIFT IS INSTALLED.

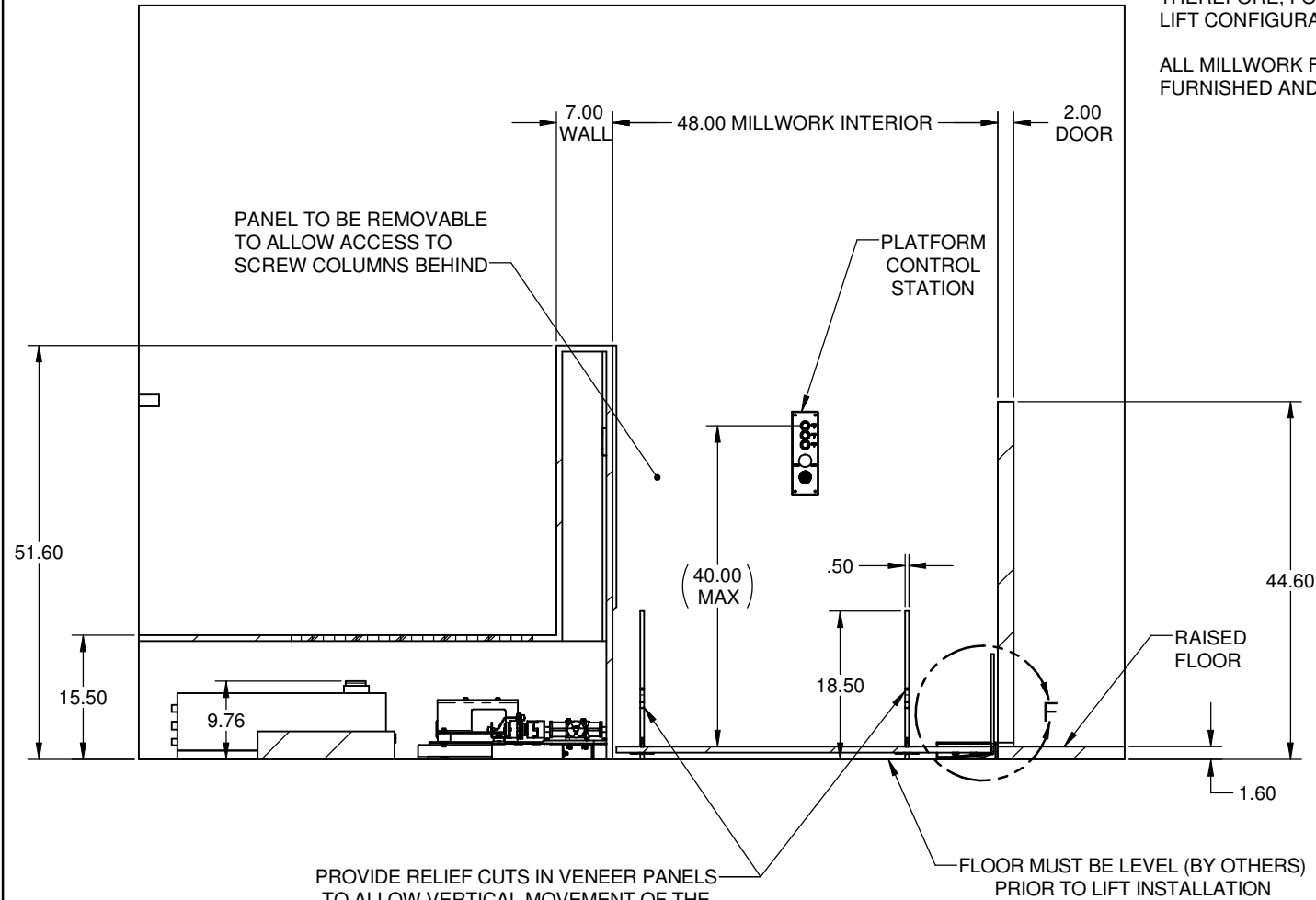

SECTION A-A

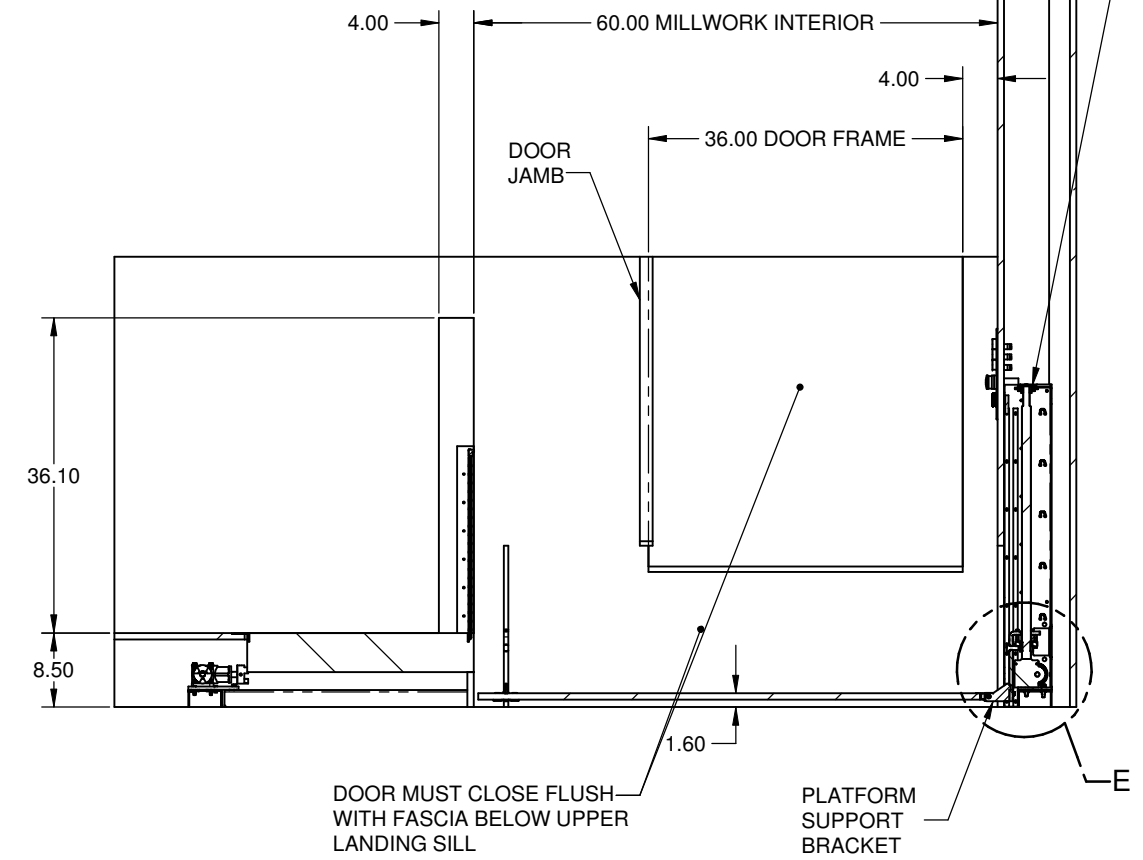

SECTION B-B

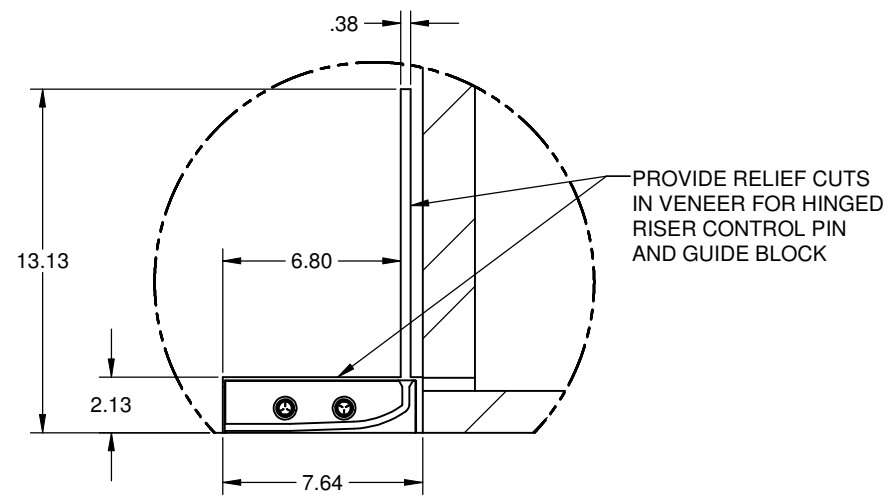

DETAIL F

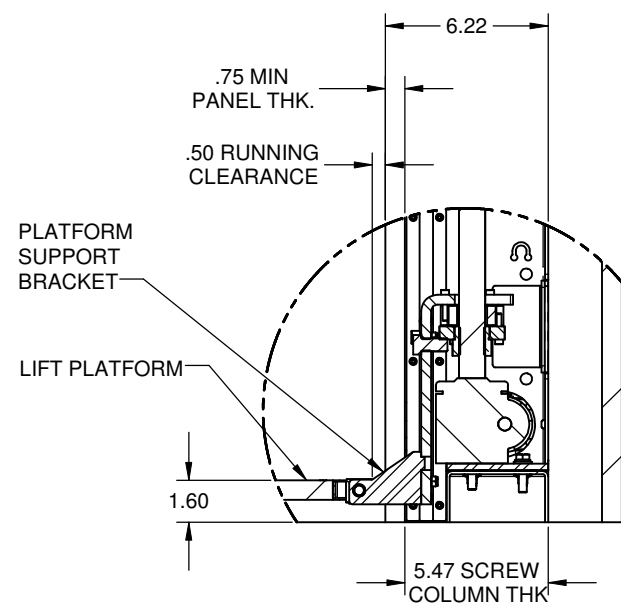

DETAIL E

REFERENCE ONLY

 LIFT-U P.O. BOX 398 ESCALON, CA. 95320 209-838-2400	THIS DOCUMENT IS AND CONTAINS CONFIDENTIAL TRADE SECRET INFORMATION OF THE COMPANY. NO PART OF IT MAY BE REPRODUCED, STORED IN A RETRIEVAL SYSTEM, OR TRANSMITTED IN ANY FORM OR BY ANY MEANS ELECTRONICALLY, PHOTOCOPIING, RECORDING OR OTHERWISE, WITHOUT THE PRIOR WRITTEN PERMISSION OF HOGAN MFG., INC. THIS DOCUMENT IS LOANED FOR THE LIMITED PURPOSES STATED HEREIN ONLY, AND REMAINS THE PROPERTY OF THE COMPANY.	
	A DIVISION OF HOGAN MFG., INC.	
TITLE LIFT CONFIGURATION, 7"-14" RISE		
DOCUMENT NO.	910-0091	SHEET NO. 2 OF 5
		REVISION A

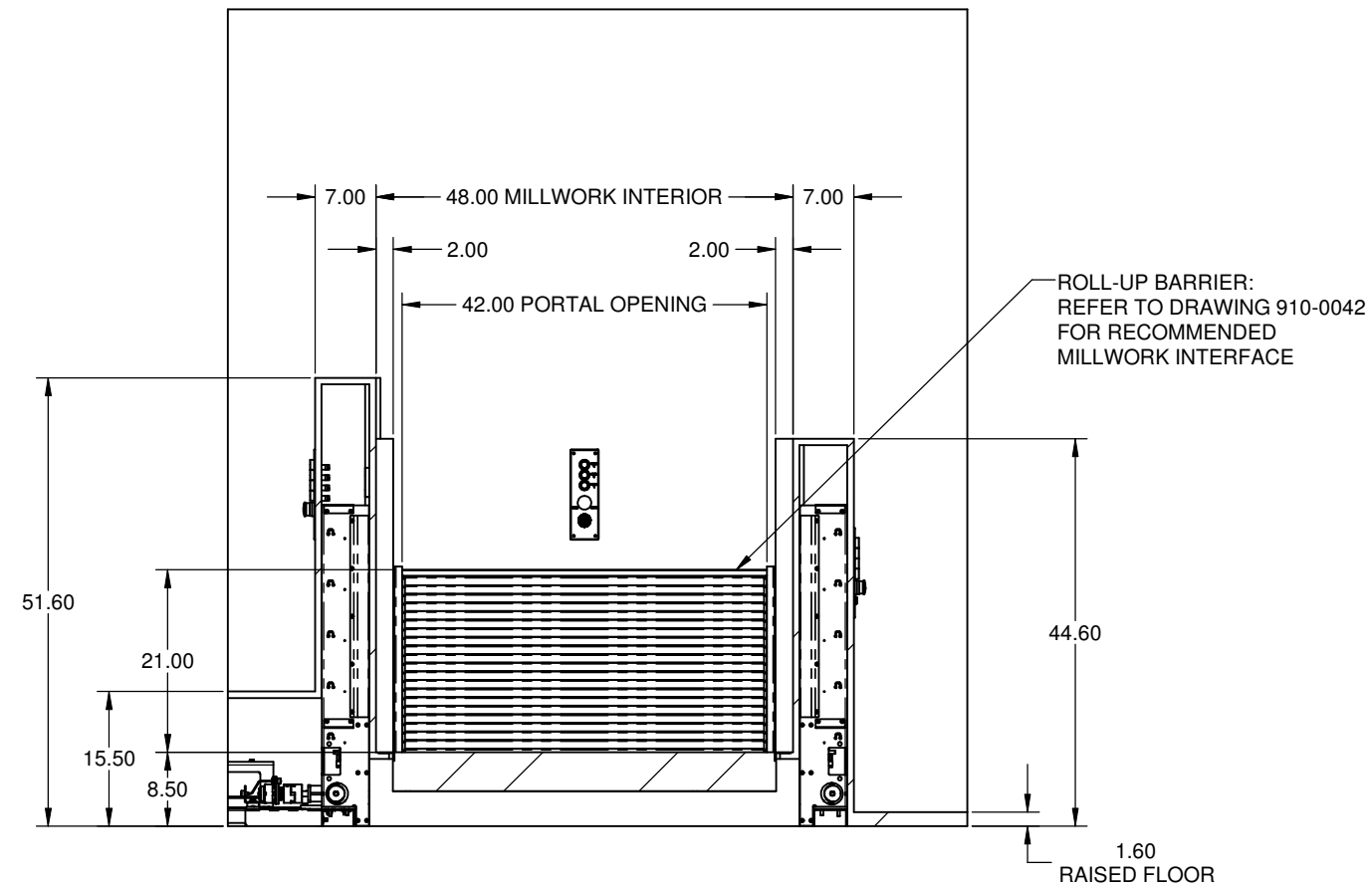

SECTION C-C

REFERENCE ONLY

NOTES:

THIS DRAWING IS GENERIC AND PROVIDED TO ILLUSTRATE LIFT-U'S RECOMMENDED VMW LIFT / MILLWORK INTERFACE.

THE DIMENSIONS AND DETAILS WILL VARY FOR EACH APPLICATION. THEREFORE, FOR EACH PROJECT APPLICATION REFER TO ITS CORRESPONDING LIFT CONFIGURATION DRAWING FOR GENERAL ARRANGEMENT LAYOUT AND LIFT ENVELOPE DIMENSIONS.

ALL MILLWORK FRAMING AND VENEERED PANEL FINISHES ENCASING THE LIFT ARE FURNISHED AND INSTALLED BY OTHERS.

 LIFT-U <small>P.O. BOX 398 ESCALON, CA. 95320 209-838-2400</small>	<small>THIS DOCUMENT IS AND CONTAINS CONFIDENTIAL TRADE SECRET INFORMATION OF THE COMPANY. NO PART OF IT MAY BE REPRODUCED, STORED IN A RETRIEVAL SYSTEM, OR TRANSMITTED IN ANY FORM OR BY ANY MEANS ELECTRONICALLY, PHOTOCOPYING, RECORDING OR OTHERWISE, WITHOUT THE PRIOR WRITTEN PERMISSION OF HOGAN MFG, INC. THIS DOCUMENT IS LOANED FOR THE LIMITED PURPOSES STATED HEREIN ONLY, AND REMAINS THE PROPERTY OF THE COMPANY.</small>	
	<small>A DIVISION OF</small> HOGAN MFG., INC.	
TITLE LIFT CONFIGURATION, 7"-14" RISE		
DOCUMENT NO. 910-0091	SHEET NO. 3 OF 5	REVISION A

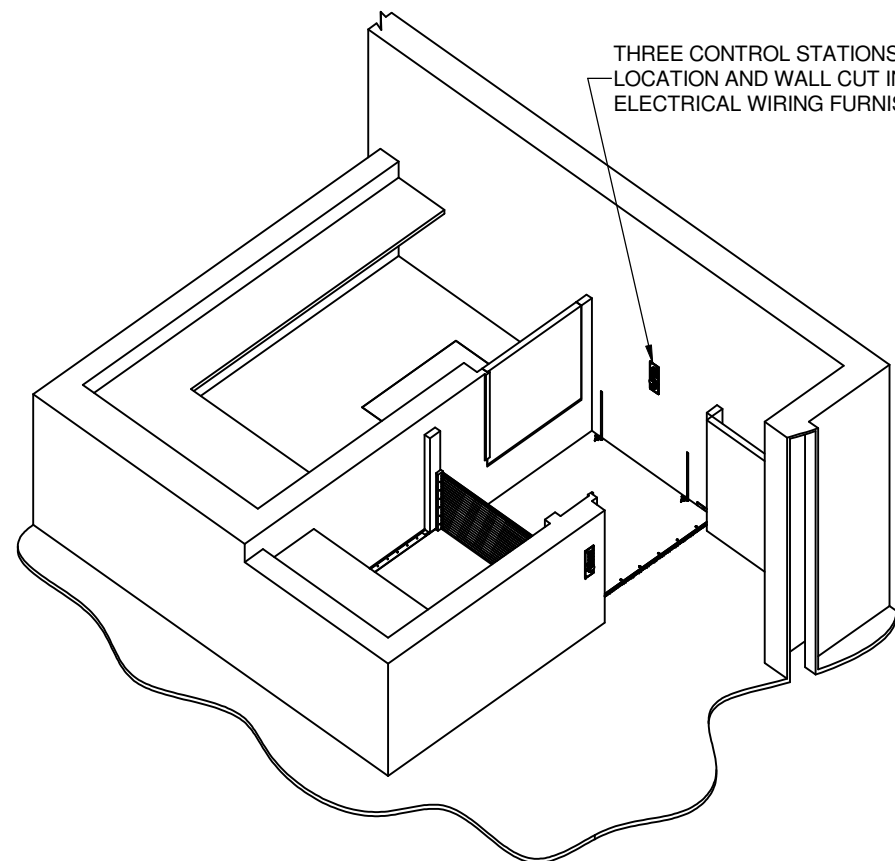

PLATFORM SHOWN AT LOWER LEVEL (1)
READY FOR PASSENGER INGRESS OR EGRESS

THREE CONTROL STATIONS SUPPLIED BY LIFT-U.
LOCATION AND WALL CUT IN BY OTHERS.
ELECTRICAL WIRING FURNISHED BY LIFT-U.

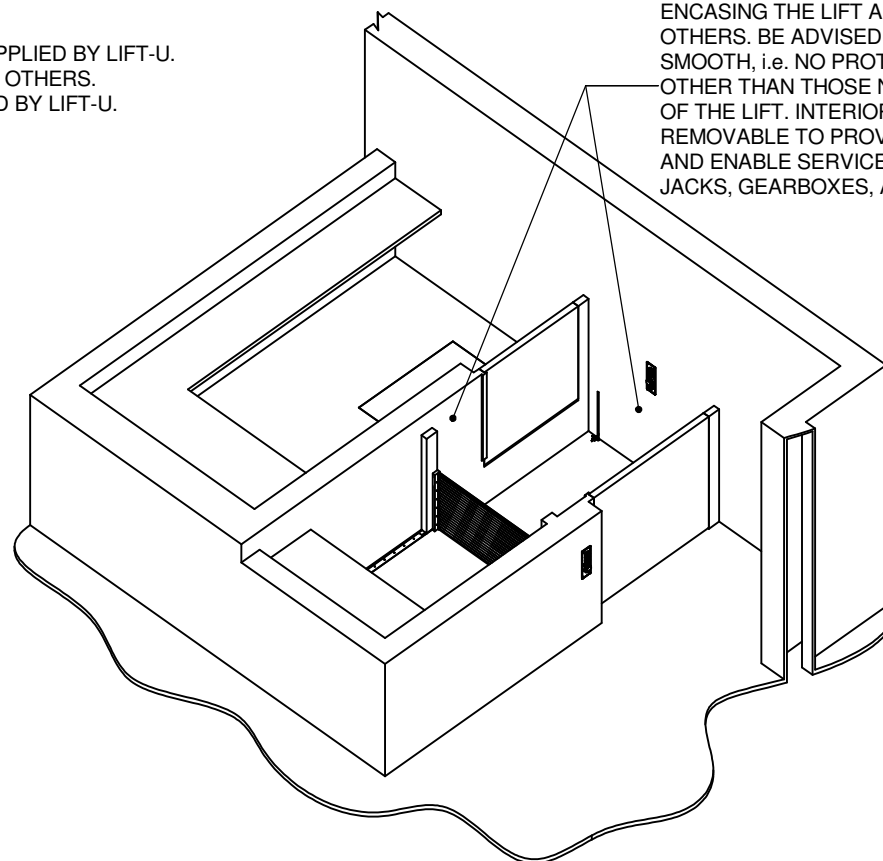

DOORS ARE CLOSED AND LOCKED WHEN
PLATFORM RAISES AND LOWERS

ALL MILLWORK FRAMING AND VENEERED PANEL FINISHES
ENCASING THE LIFT ARE FURNISHED AND INSTALLED BY
OTHERS. BE ADVISED - ALL INTERIOR SURFACES MUST BE
SMOOTH, i.e. NO PROTRUSIONS AND NO OPENINGS,
OTHER THAN THOSE NECESSARY FOR THE OPERATION
OF THE LIFT. INTERIOR PANELS SHOULD BE MADE
REMOVABLE TO PROVIDE ACCESS TO LEVEL SWITCHES
AND ENABLE SERVICE OR REPLACEMENT OF SCREW
JACKS, GEARBOXES, AND DRIVE SHAFTS.

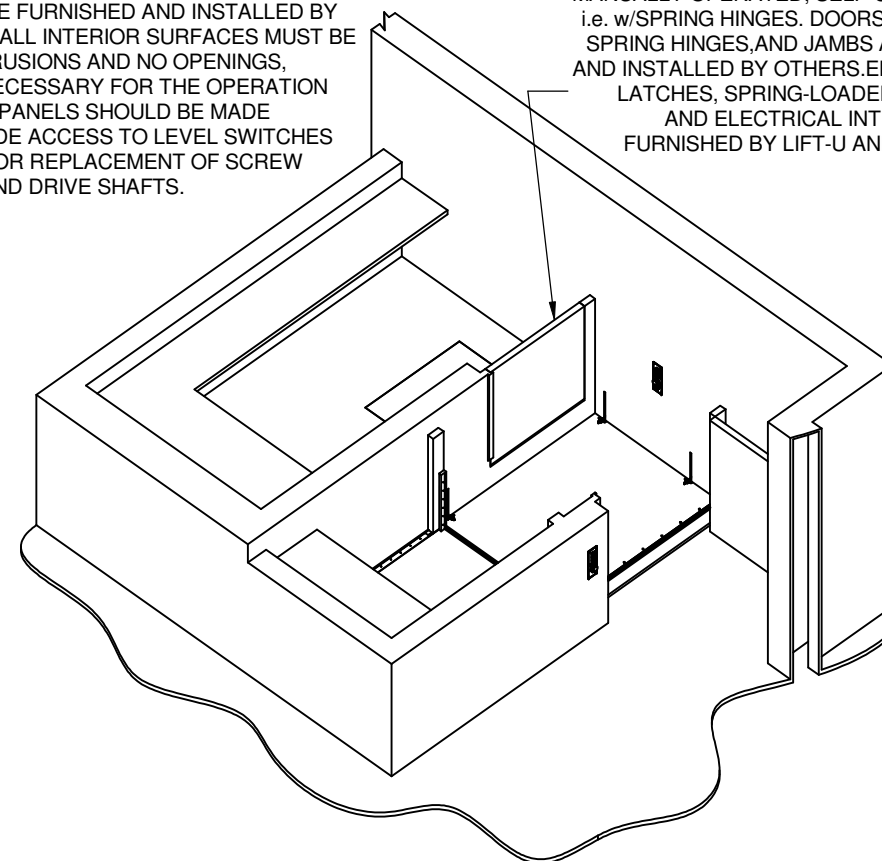

PLATFORM SHOWN PARKED AT WITNESS
LEVEL (2) FOR USE BY ABLE-BODIED PERSONS

MANUALLY OPERATED, SELF-CLOSING DOORS
i.e. w/SPRING HINGES. DOORS, SELF-CLOSING
SPRING HINGES, AND JAMBS ARE FURNISHED
AND INSTALLED BY OTHERS. ELECTRIC STRIKE
LATCHES, SPRING-LOADED LATCH BOLTS,
AND ELECTRICAL INTERLOCK WIRING
FURNISHED BY LIFT-U AND INSTALLED BY
OTHERS.

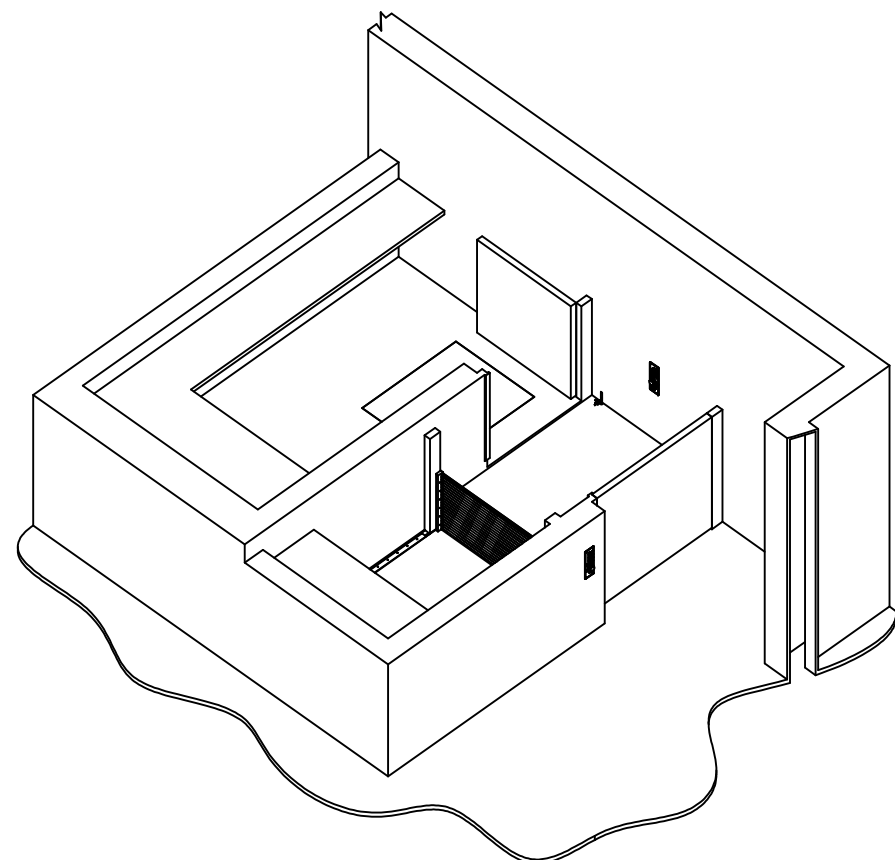

PLATFORM SHOWN AT UPPER LEVEL (3)
READY FOR PASSENGER INGRESS OR EGRESS

PROVIDE AN ACCESS HATCH TO ENABLE
SERVICE ON MOTOR AND ELECTRONICS
LOCATED BELOW UPPER LANDING.
HATCH SHOULD BE NO LESS THAN 30" x 36".
A REMOVABLE JOIST WITHIN THE FRAMED
HATCH OPENING SHOULD BE POSITIONED
TO REINFORCE THE HATCH COVER.

NOTES:

THIS DRAWING IS GENERIC AND PROVIDED TO ILLUSTRATE LIFT-U'S RECOMMENDED
VMW LIFT / MILLWORK INTERFACE.

THE DIMENSIONS AND DETAILS WILL VARY FOR EACH APPLICATION.
THEREFORE, FOR EACH PROJECT APPLICATION REFER TO ITS CORRESPONDING
LIFT CONFIGURATION DRAWING FOR GENERAL ARRANGEMENT LAYOUT AND LIFT ENVELOPE DIMENSIONS.

ALL MILLWORK FRAMING AND VENEERED PANEL FINISHES ENCASING THE LIFT ARE
FURNISHED AND INSTALLED BY OTHERS.

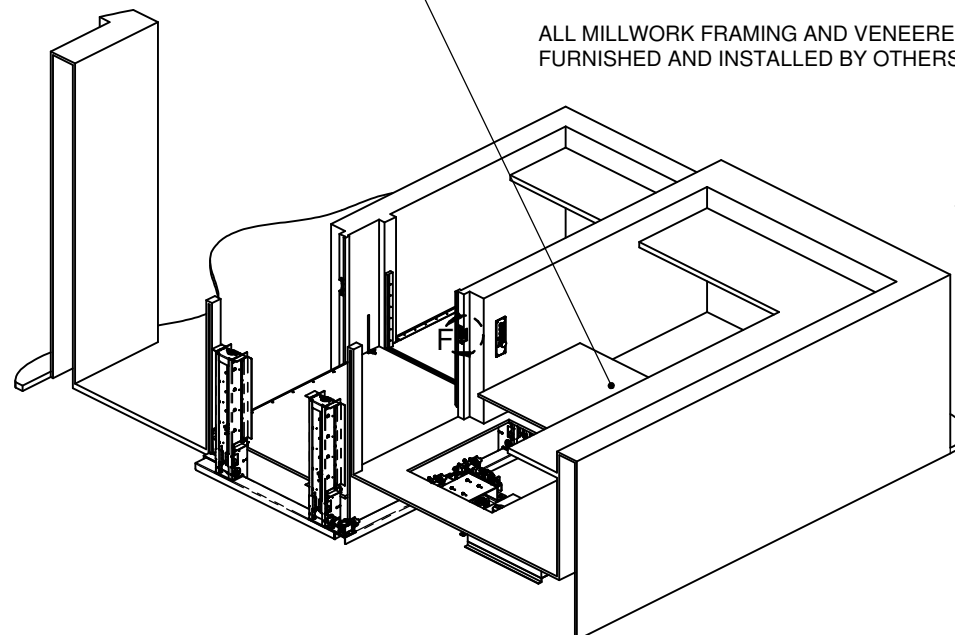

REVERSE ISOMETRIC VIEW
BACK WALL AND DOORS NOT SHOWN FOR CLARITY

REFERENCE ONLY

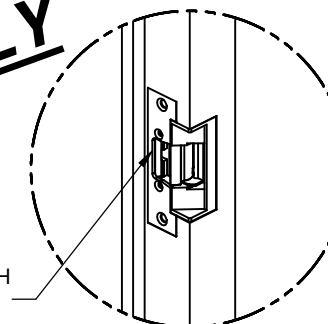

ELECTRIC STRICK LATCH
CUT INTO DOOR JAMB

DETAIL F
TYPICAL 2 PLACES



A DIVISION OF
HOGAN MFG., INC.

THIS DOCUMENT IS AND CONTAINS CONFIDENTIAL
TRADE SECRET INFORMATION OF THE COMPANY. NO
PART OF IT MAY BE REPRODUCED, STORED IN A
RETRIEVAL SYSTEM, OR TRANSMITTED IN ANY FORM
OR BY ANY MEANS ELECTRONICALLY, PHOTOCOPYING,
RECORDING OR OTHERWISE, WITHOUT THE PRIOR
WRITTEN PERMISSION OF HOGAN MFG., INC.
THIS DOCUMENT IS LOANED FOR THE LIMITED
PURPOSES STATED HEREIN ONLY, AND REMAINS
THE PROPERTY OF THE COMPANY.

TITLE	LIFT CONFIGURATION, 7"-14" RISE		
DOCUMENT NO.	910-0091	SHEET NO.	4 OF 5
		REVISION	A

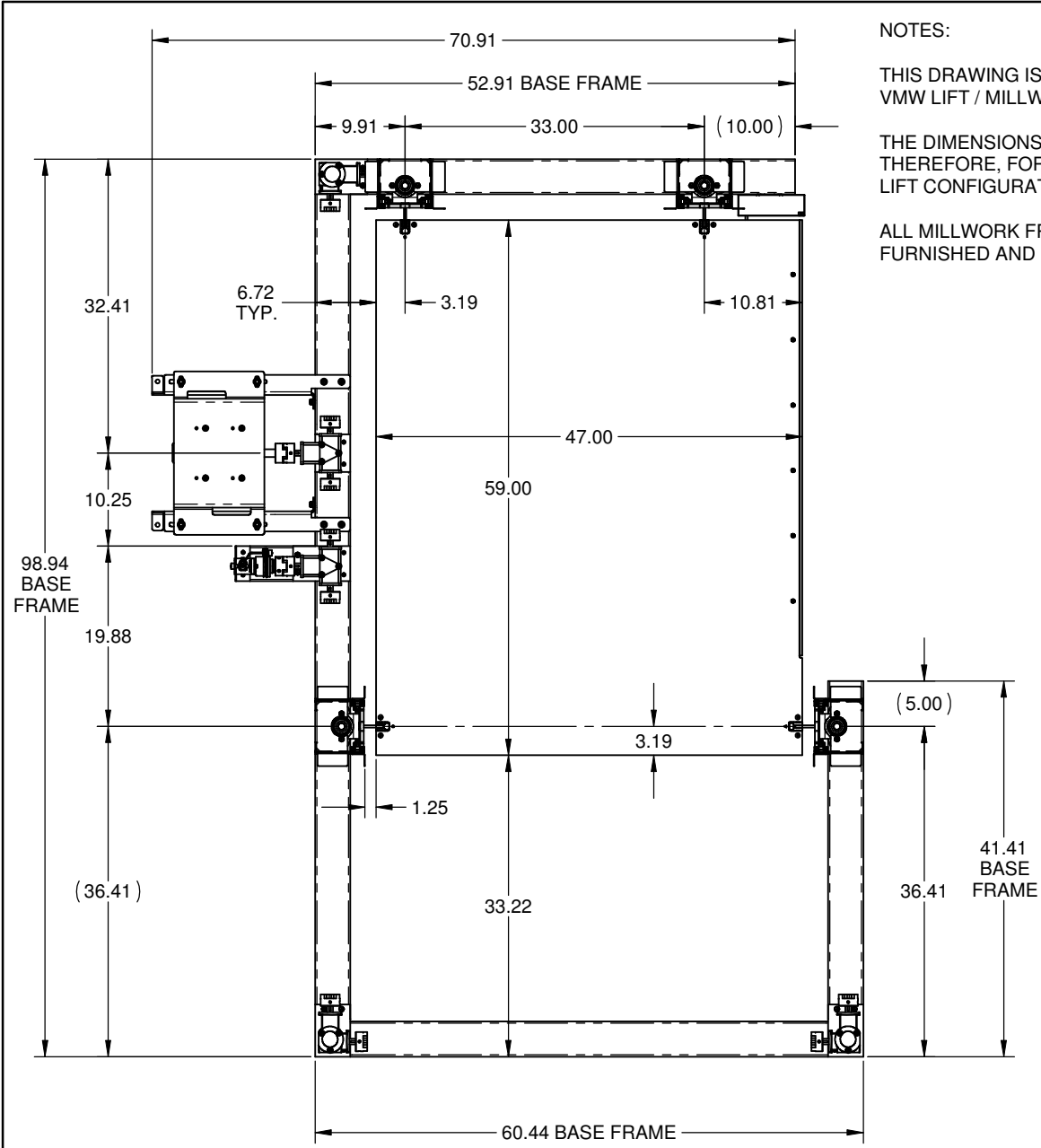

NOTES:
 THIS DRAWING IS GENERIC AND PROVIDED TO ILLUSTRATE LIFT-U'S RECOMMENDED VMW LIFT / MILLWORK INTERFACE.
 THE DIMENSIONS AND DETAILS WILL VARY FOR EACH APPLICATION. THEREFORE, FOR EACH PROJECT APPLICATION REFER TO ITS CORRESPONDING LIFT CONFIGURATION DRAWING FOR GENERAL ARRANGEMENT LAYOUT AND LIFT ENVELOPE DIMENSIONS.
 ALL MILLWORK FRAMING AND VENEERED PANEL FINISHES ENCASING THE LIFT ARE FURNISHED AND INSTALLED BY OTHERS.

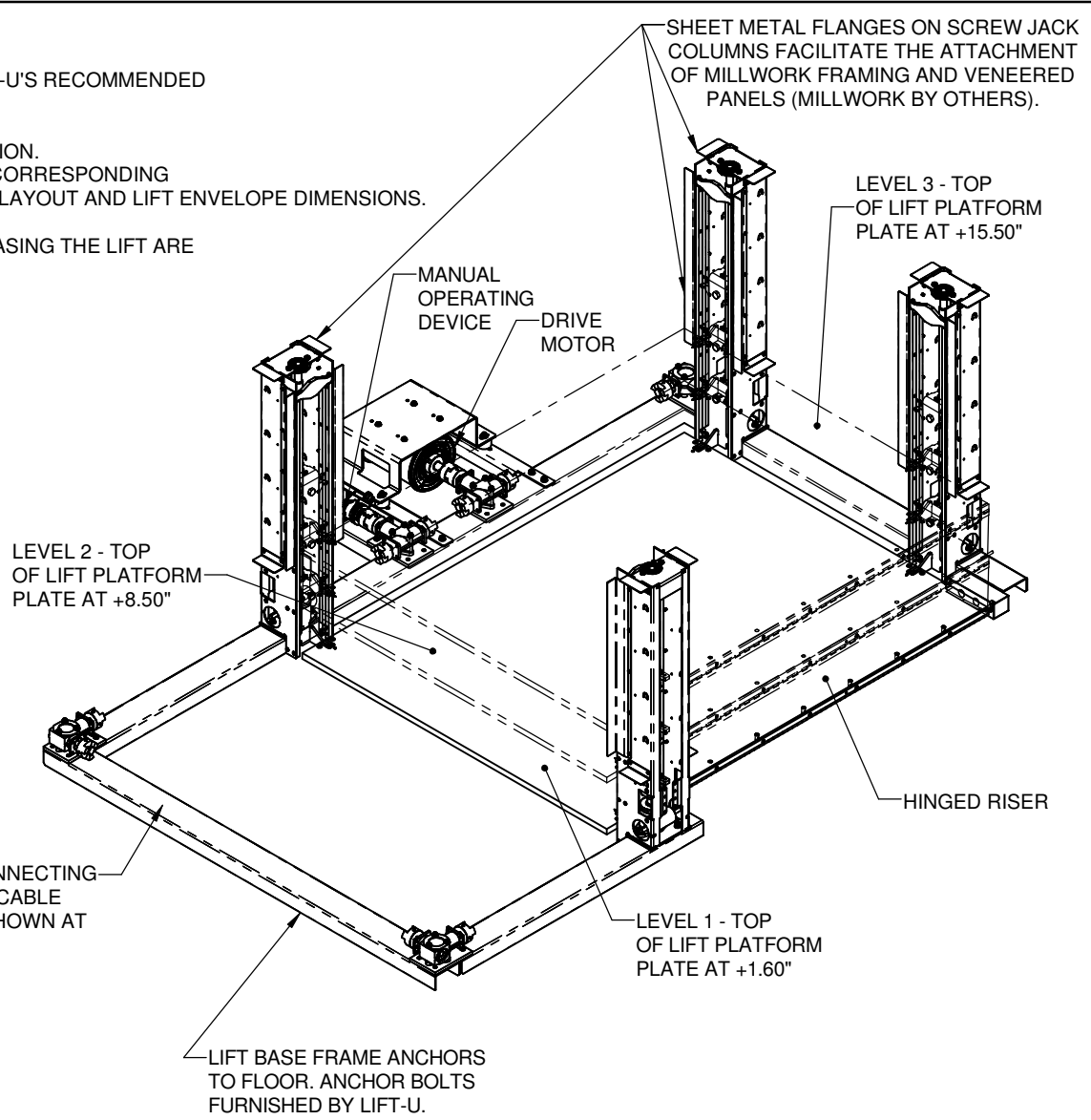

ISOMETRIC VIEW

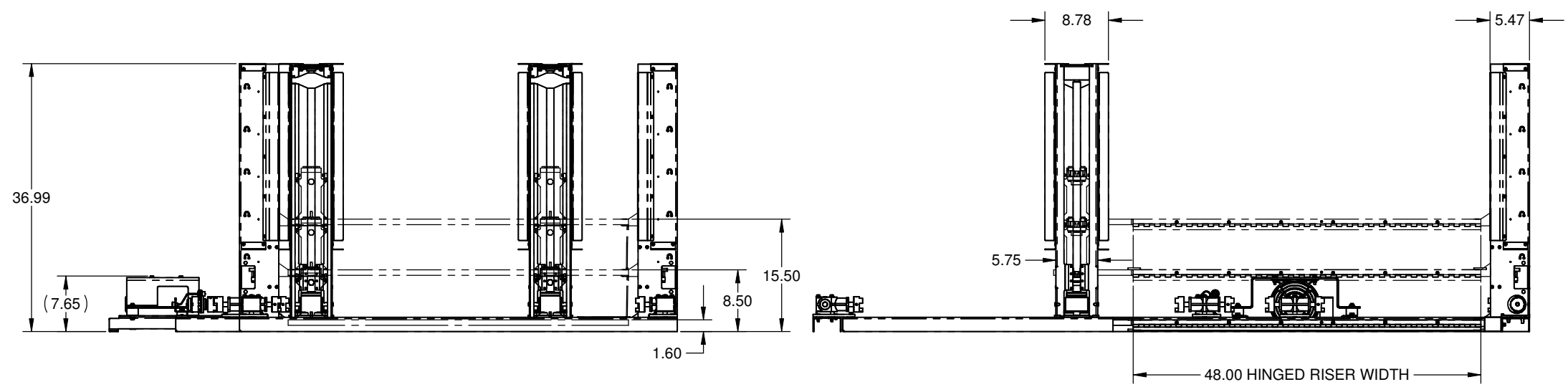

LIFT ENVELOPE DIMENSIONS

REFERENCE ONLY

	LIFT-U P.O. BOX 398 ESCALON, CA. 95320 209-838-2400	THIS DOCUMENT IS AND CONTAINS CONFIDENTIAL TRADE SECRET INFORMATION OF THE COMPANY. NO PART OF IT MAY BE REPRODUCED, STORED IN A RETRIEVAL SYSTEM, OR TRANSMITTED IN ANY FORM OR BY ANY MEANS ELECTRONICALLY, PHOTOCOPYING, RECORDING OR OTHERWISE, WITHOUT THE PRIOR WRITTEN PERMISSION OF HOGAN MFG., INC. THIS DOCUMENT IS LOANED FOR THE LIMITED PURPOSES STATED HEREIN ONLY, AND REMAINS THE PROPERTY OF THE COMPANY.
	A DIVISION OF HOGAN MFG., INC.	
TITLE LIFT CONFIGURATION, 7"-14" RISE		
DOCUMENT NO. 910-0091	SHEET NO. 5 OF 5	REVISION A