

⚠ WARNING

1. Read all instructions for future reference.
2. Follow all warnings and instructions marked on the product.
3. Do not stand on the VersaHaul.
4. Do not ride any vehicle while loading onto the VersaHaul.
5. Always store the VersaHaul carrier in a safe place.
6. Never exceed vehicle tongue weight ratings.
7. Only use VersaHaul with Class 3 or 4 hitch. Most Class 3 hitches limit the VersaHaul to 500 lbs. total hauling capacity.
8. Improper use, storage or installation of carrier could result in death or serious injury.
9. Do not put any VersaHaul on a 5th wheel trailer or any other kind of trailer.
10. VH-55 carrying capacity is limited to 500 lbs. max. Your vehicle suspension and hitch may limit the hauling capacity of the carrier. For more information on vehicles and hauling capacities, visit www.versahaul.com.

LIMITED WARRANTY

The Limited Warranty on the VersaHaul Carrier.

BNK, INC warrants the carrier and related components. This warranty applies to any part found to be defective due to material and/or workmanship when inspected at the factory of BNK, Inc., Winamac, IN. BNK Inc. will, at its option, repair or replace defective parts to the original purchaser at no charge other than transportation. Sale receipt as proof of date of purchase is required, which will be returned. BNK, Inc. assumes no liability for labor charges made in performance of this warranty.

The warranty periods are as follows from date of purchase:

CARRIER FOR 1 YEAR, VOID IF: frame is broken or bent due to abuse. example: (underside scraped abusively)

ALL WARRANTIES ARE VOID IF: the carrier has been rented, used under abnormal conditions, or subjected to abuse, misuse, neglect, or improper maintenance.

All warranties should be handled at point of purchase unless other arrangements are made.

BNK, Inc. is not liable for any damage claim or liability claim, personal or otherwise resulting from operation of this carrier in any way. All transportation charges for items returned for warranty evaluation and/or replacement are to be borne by the customer.

For one (1) year from the date of purchase, BNK, Inc. will repair or replace for the original purchaser, without charge, any part or parts are manufactured by BNK, Inc. and found, upon examination at our factory in Winamac, to be defective in materials and/or workmanship.

All transportation charges on parts submitted for replacement under this warranty must be borne by the purchaser. This warranty does not apply to parts not manufactured by BNK, Inc. Their manufacturer may warrant these items. This warranty does not apply to any part which has been damaged by accident, alteration, abuse, improper adjustment, normal wear, or any other cause beyond our control.

Use of replacement parts other than genuine BNK, Inc. parts may impair the safety of your machine and void this warranty.

IMPORTANT

THIS WARRANTY IS VOID UNLESS THE PRODUCT REGISTRATION CARD IS FILLED OUT COMPLETELY AND RETURNED TO THE FACTORY AT WINAMAC, IN. WITHIN TEN (10) DAYS OF PURCHASE.

OUR WARRANTY COVERS OUR PRODUCT FOR ONE YEAR. WE ARE NOT ABLE TO EXCHANGE USED VERSAHAUL CARRIERS FOR REFUNDS OR NEW CARRIERS.

PARTS

NOTE: VersaHaul is attached with your standard Hitch Pin (not included).

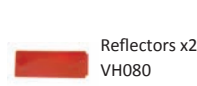
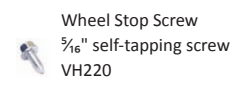
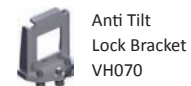
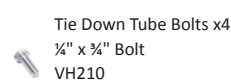
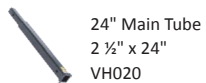
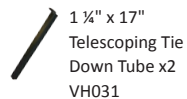
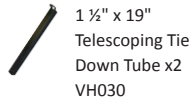

TOOLS



ASSEMBLING YOUR VERSAHAUL

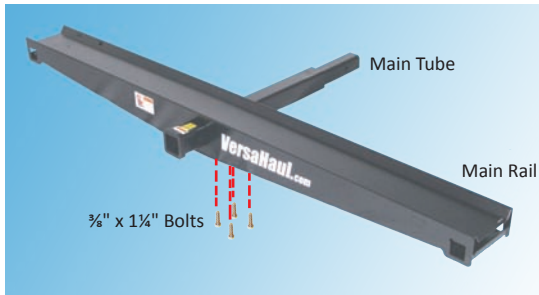

Step 1
 Note: If you have a VH-TK taillight kit, please refer to the VH-TK instructions at this time. Insert the 24" Main Tube into the Main Rail using the $\frac{3}{8}$ " x $1\frac{1}{4}$ " Bolts to fasten the assembly. Tighten the bolts until snug; DO NOT over tighten. Note: The "This Side Up" sticker and circular weld spot should be facing up. The tubes are welded so that the carrier sticks out from the hitch receiver with an incline. If installed upside down, it will decline.



Step 2
 Insert the Wheel Stop into the slots. Lock the Wheel Stop into place with a $\frac{5}{16}$ " Wheel Stop Screw. **Note:** Do NOT over tighten. There are two positions for the Wheel Stop to help center the motorcycle/scooter.

Step 3
 Insert the $1\frac{1}{2}$ " x 19" Tie Down Tube through the Main Rail. Then insert the $1\frac{1}{4}$ " x 17" Tie Down Tube into the $1\frac{1}{2}$ " x 19" Tie Down Tube. Lock into place with a Snap Pin. Secure the Tie Down Tubes with two $\frac{1}{4}$ " x $\frac{3}{4}$ " Bolts. Do this for both ends (Figure 3.1 and 3.2).

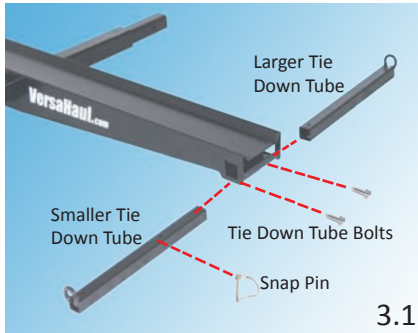

3.1

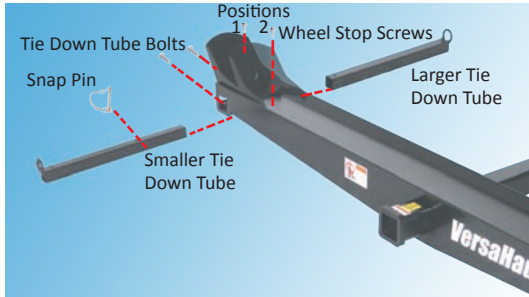

3.2

Assembled VH-55 carrier with Tie Down Tubes extended



Remove Reflector backing and affix Reflectors as shown.



VH-55 carrier in use.

ATTACHING YOUR VERSAHAUL



Step 1
 Mount the three $\frac{3}{8}$ " bolts to the included Anti-Tilt Lock Bracket. Insert bracket to the main tube as shown.



Step 2
 Insert main tube into vehicle's receiver hitch and install hitch pin (not included).



Step 3
 Put the bracket flush against the hitch collar. Tighten the center bolt until it fits snugly against the receiver hitch underside. Tighten the two side bolts; then re-tighten the center bolt. Make sure all bolts are tight enough such that no slack exists between the main tube and the hitch. **Note:** Road vibration may cause bolts to loosen over time. Test by rocking the carrier from the sides. Minor deformation is normal on the contact area between the main tube and the anti-tilt bracket.

Alternative Instructions

If the Anti-Tilt Lock Bracket does not fit, use the Anti-Tilt Hitch Attachment Bolt. The Anti-Tilt Hitch Attachment Bolt has a $\frac{7}{18}$ " thread size, a $\frac{3}{8}$ " Allen Head size, and a $\frac{5}{8}$ " outer head size. Slide the Main Tube of the carrier into the hitch receiver. Secure the Main Tube to the receiver with the Anti-Tilt Bolt, Washer and Nut. The Bolt must be inserted into the $\frac{7}{16}$ " hole, not the $\frac{5}{8}$ " hole. **Note:** Do not put a washer at the bolt head, but rather at the nut. The bolt head should be recessed into the receiver hole and be putting pressure on the Main Tube of the Carrier inside the receiver.

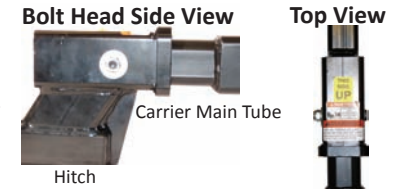

The Taillight Kit with License Plate Light is available for purchase (sold separately).



The VH-55 Ramp Option is available for purchase (sold separately).



Tow up to 3000 lbs. behind the single motorcycle carrier. Strict weight limits apply.

SPECIAL FEATURES

NOTE: WHEN ATTACHING STRAPS TO TIE-DOWN TUBES

When attaching the tie down straps, securely hook the straps from the center of the handlebars to the eyelets located on the tie-down tubes. Be sure to evenly tighten the straps on both sides of the motorcycle. Do not hook the straps to the ends of the handlebars. Improper placement of the straps will lead to the motorcycle tipping.

