

# Surfer Bather

Patents Pending

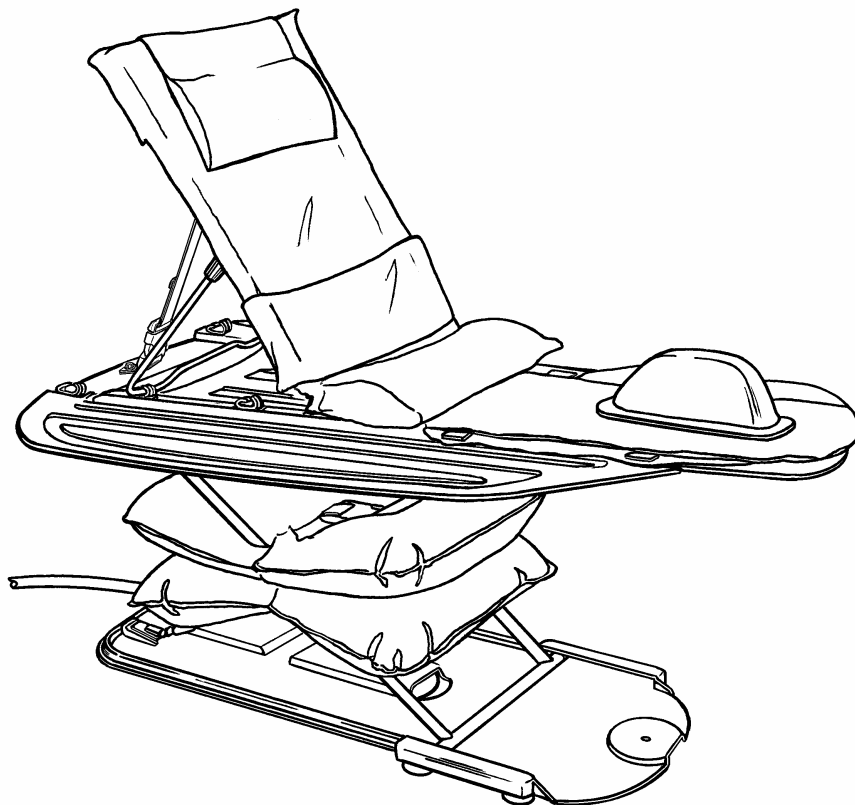

## Instructions for use



USA & CAN

The Mangar Surfer Bather is a pneumatically powered elevating bathing platform designed to assist in the bathing of children. The Surfer Bather is particularly suitable for children with limited upper body stability. The adjustable backrest, together with straps if necessary, provides full support. The pneumatic lift is powered by the Mangar Airflo compressor. **DO READ** the separate compressor instructions before using your Surfer Bather.

**WARNING:** The Surfer Bather has been designed to be used in a conventional bathtub. Some types of corner tub and 'spa' tubs which produce multi-jets of water, are not suitable for its use, as the suction cups may not adhere properly. If the Surfer Bather is to be used in a different bathtub from that in which it is normally used, check for suitability of use and that the suction cups adhere properly.

**STANDARD CONTENTS LIST (Fig.1)**

- 1 x Surfer Bather platform (A).
- 1 x Scissor lift (including bellows and base board) (B).
- 1 x Backrest (including Headrest pad) (C).
- 1 x Platform Pad (D).
- 1 x Support strap (E).
- 1 x Instructions for use.
- 1 x Airflo compressor (inc. user instructions).

**Optional extras:**

- Platform Pad with rails (G) for extra support strap.
- Head Support (not shown).
- Pommel (F).
- Carrying bag (not shown).

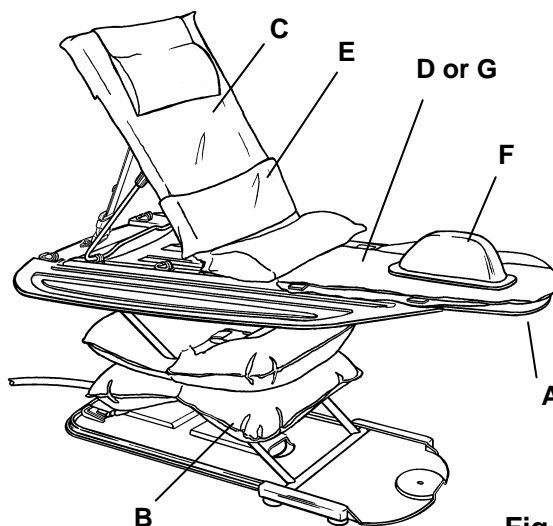

Fig 1

**PLEASE NOTE:** The platform flaps may become stiff following long periods of storage, this can be cured by fully opening and then closing each flap, repeating as necessary until each flap moves easily.

**Fitting the Surfer Bather in the bathtub (Figs. 2 & 3)**

**WARNING:** Ensure that the locking catches are in the locked position before placing the Surfer Bather in the bathtub (Fig.2).

- Place the deflated Surfer Bather in the bathtub so that the rear of the base board is as close to the non-tap end of the tub as it will go without resting on the curve of the tub (A Fig.3). **Press down on the Surfer Bather to secure the base board suction cups firmly to the tub.**
- Fully inflate the bellows and check that the narrow end of the platform has adequate clearance, between it and any overhanging taps (B fig.3).

**WARNING:** Always ensure that the suction cups are correctly positioned and are adhering to the bathtub before use.

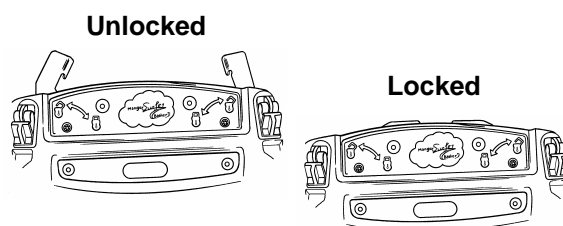

Fig.2

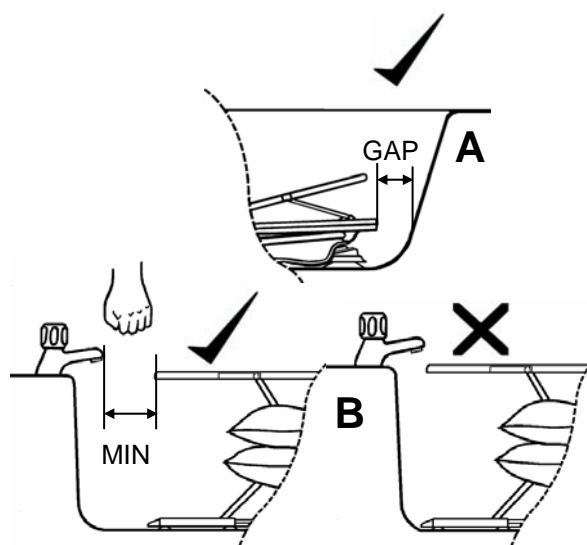



Fig.3

### **WARNINGS:**

- Ensure that the child's limbs are well within the platform area before raising or lowering the Surfer Bather.
- NEVER leave a child unattended whilst they are on the Surfer Bather.
- DO NOT use outside of the bathtub.

### **To raise and lower the Surfer Bather**

- To raise the Surfer Bather, press 'up'  on the Airflo hand control (Fig.4).
- To stop at any point, release the 'up' button.
- To lower the Surfer Bather, press 'down' . **NOTE:** If the Surfer Bather platform rises after reaching the bottom of the bathtub, press the down button again and keep it held until the remaining air is expelled from the bellows.

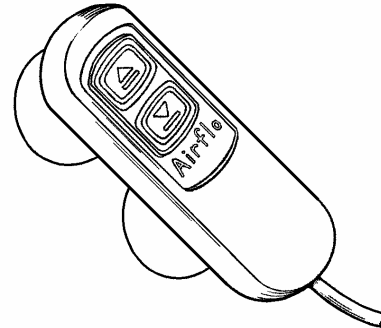

**Fig. 4**

### **Fitting/Adjustment of Backrest and Platform Pad**

- The backrest and the platform pad are secured to the platform by means of plastic lugs inserted into keyhole slots. Locate and slide the lug into the slot as indicated (1 & 2 fig.5), press the locking tag down so that it 'clicks' into place (3 fig.5).
- Fit the backrest hinges to the slots (A or B fig.6) **NOTE:** If the forward slots (B) are to be used, transfer the two 'blanking plugs' to the rear slots (A).
- Adjust the backrest angle by locating the support bar in any of the three catches (C fig.5). The backrest can be fully lowered by releasing the support bar from the catches and allowing the backrest to lie flat.
- Adjust the backrest angle to the required position and connect the buckle on the backrest restraint strap (A Fig.7). Tension the strap in order to lock the backrest angle. If the backrest angle needs to be changed, unfasten the buckle before resetting the angle. Re-connect the buckle and tighten the strap to lock the backrest at its new angle.
- Fit the platform pad (D fig.5) by inserting the plastic lugs into the forward slots first (E fig. 6), followed by the slots (F fig. 6). **NOTE:** If fitting the optional platform pad with rails (G fig.1) the rear lugs do not have locking tags.

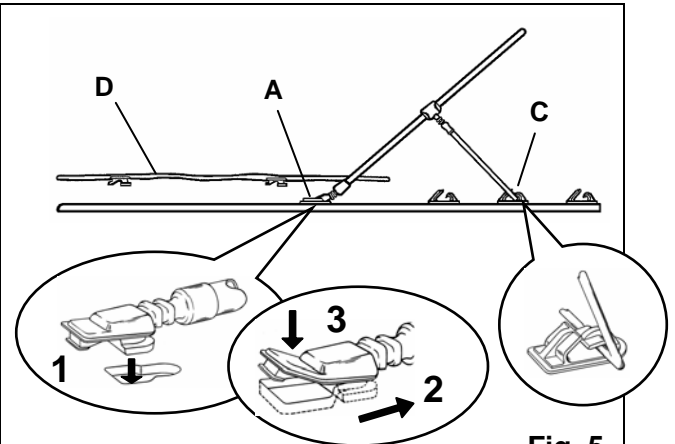

**Fig. 5**

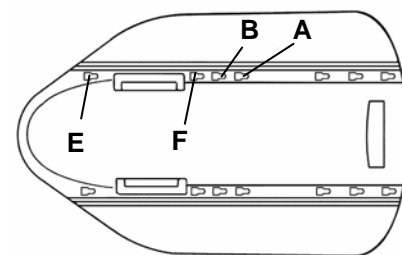

**Fig. 6**

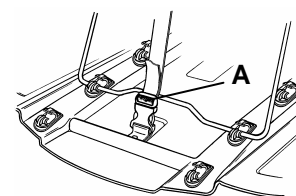

**Fig. 7**

To unfasten the plastic lugs in order to remove the backrest and platform pad:-

- Locate the locking tag from the underside of the platform and press it up (1 fig.8).
- Slide and lift the lug clear of the slot (2 & 3 fig.8).

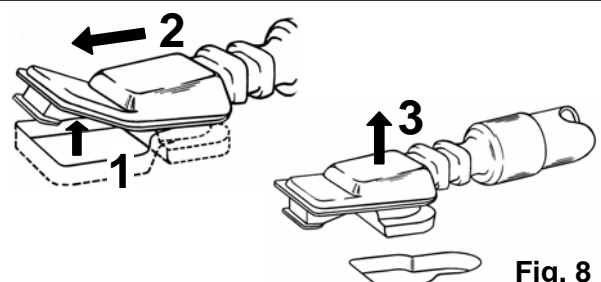

**Fig. 8**

### To remove the Surfer Bather from the bathtub

- Drain the bathtub water.
- To aid removal from the bathtub, the platform should be separated from the scissor lift. Partially elevate the Surfer Bather and pull the locking catch levers fully out (Fig.2) to unlock the platform from the scissor lift. Unclip the platform from the scissor lift (1 fig.9). Swivel the platform as indicated (2 fig.9) to disengage the bars from the slots on the underside of the platform.

**NOTE:** The locking catches must be released before attempting to separate the platform from the scissors.

- Lift the rim on each of the two large suction cups on the base board to release the suction between suction cup and bathtub (A Fig.10) and remove the scissor assembly from the tub.
- The four small suction cups on the base board will release their suction as the scissor assembly is lifted from the tub.

**NOTE:** Never attempt to remove the Surfer Bather from the bathtub without first breaking the suction under each of the two large base board suction cups or damage will result.

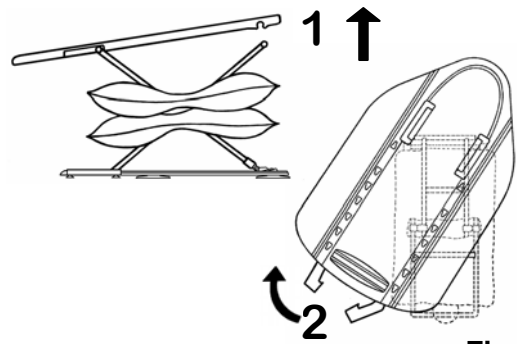

Fig. 9

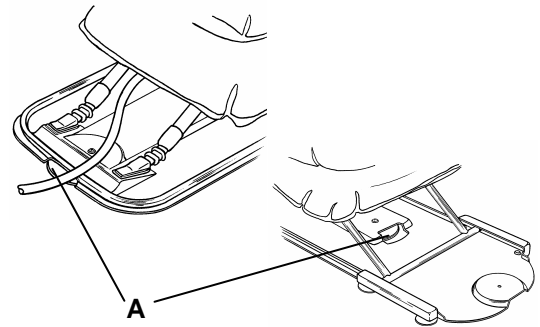

Fig. 10

### Re-fitting the Netting to the Backrest Frame after laundering

- Insert the thigh support foam (A fig.11) in the netting lower pocket.
- Insert the backrest frame into the pocket of the netting (B) and fasten the four buckles (C).
- Tighten or slacken the buckle straps in order to adjust the tension of the netting on the backrest frame.
- Insert the headrest foam (D) in the pocket of the headrest netting and if required, Velcro™ the headrest to the backrest.
- The support strap (E) can be attached to the Velcro™ panel (F) as required.

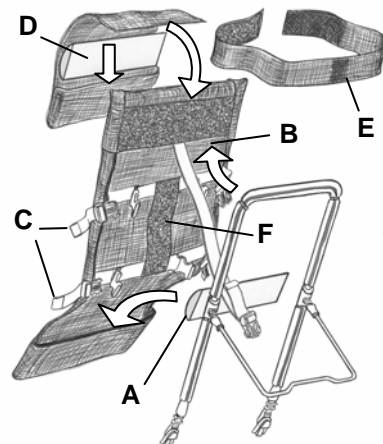

Fig. 11

**ROUTINE CLEANING** – After use, fully inflate and rinse with clear water to remove soaps and impurities. The Surfer Bather can be cleaned with a proprietary liquid cleaner or disinfectant; wiped dry or left to air dry. **Do not dry using hot air.** Follow the instructions on the care label when laundering the backrest netting and straps.

**DISINFECTING** – All components should be pre-cleaned (with the bellows fully inflated) by washing with detergent and water and then disinfected using a proprietary sterilizing solution or any antibacterial cleaner. Rinse after disinfecting - **Do not dry using hot air.**

### STORAGE

**Ensure that the Surfer Bather is thoroughly dry before storing. Store deflated and in a dry place. Keep these instructions in a safe place for future reference.**

## MAINTENANCE INSTRUCTIONS

### List of Parts (Fig. 12)

- |                       |                               |
|-----------------------|-------------------------------|
| 1. Platform           | 9. Backrest assembly          |
| 2. Platform Catch     | 10. Backrest Restraint Strap. |
| 3. Scissor assembly   | 11. Backrest hinge            |
| 4. Bellows            | 12. Backrest Catch            |
| 5. Air hose           | 13. Platform Pad              |
| 6. Bellows Buckle     | 14. Relief valve              |
| 7. Large suction cups | 15. Base Board                |
| 8. Small suction cups |                               |

Fig. 12

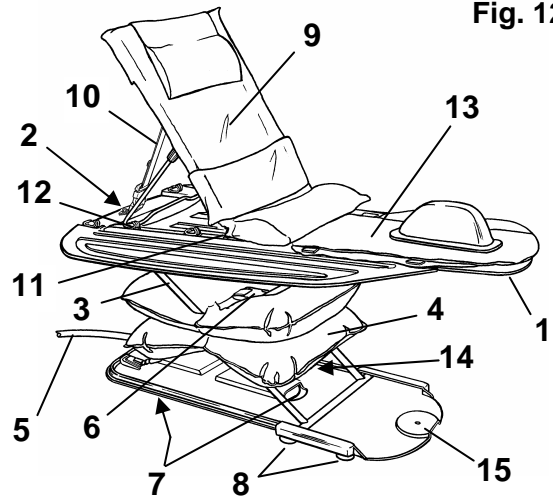

### To look after your Surfer Bather

#### regularly check that:

- The bellows buckle (6) is properly fastened and that the bellows (4) are undamaged.
- The platform catches (2) are secure and undamaged.
- The air hose (5) is undamaged.
- Both large suction cups (7) are undamaged and secure.
- The four small suction cups (8) are undamaged and secure.
- The relief valve (14) is not blocked and vents air when the bellows are fully inflated.
- That the backrest hinges (11) and catches (12) are undamaged and securely located within the slots.
- The Surfer Bather and accessories are kept clean.

### FAULT FINDING

If the Surfer Bather fails to inflate or will not stay at the chosen height, check that:

- The air hose (5) is properly connected and that the hand control is properly connected to the compressor.
- There are no kinks in the air hose and that the air hose is not trapped.
- The pressure relief valve (14) is operating properly.

### SPECIFICATIONS

- |                               |                       |
|-------------------------------|-----------------------|
| Maximum user weight:          | 110lbs                |
| Recommended Max. user height: | 4'-5"                 |
| Platform height (min-max):    | 2½"/17"               |
| Backrest angle:               | From flat to 70° max. |
| Platform assembly weight:     | 9lbs                  |
| Scissor Lift assembly weight: | 12lbs                 |
| Total weight in carrying bag: | 21lbs                 |
| Maximum Air Pressure:         | 5psi                  |

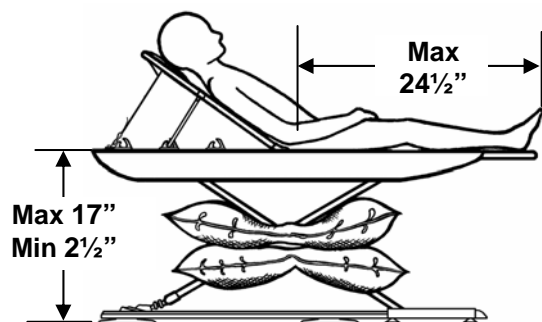



SUPPLIED BY:

Empty rectangular box for supplier information.

MANUFACTURED BY:

Mangar International

Presteigne, Powys, LD8 2UF, Wales, UK

**Tel: +44 (0) 1544 267674 Fax: +44 (0) 1544 260287**

**E-Mail: [customerservice@mangar.co.uk](mailto:customerservice@mangar.co.uk)**

**Website: [www.mangarinternational.com](http://www.mangarinternational.com)**

